



US010655095B2

(12) **United States Patent**  
**Farrish**

(10) **Patent No.:** **US 10,655,095 B2**

(45) **Date of Patent:** **May 19, 2020**

(54) **ENHANCED MACROALGAL  
PHOTOBIOREACTOR, ALGAE SCRUBBER,  
AND SEAWEED CULTIVATOR METHODS  
AND APPARATUSES—WATER DELIVERY  
STRUCTURES**

(52) **U.S. Cl.**  
CPC ..... *C12M 21/02* (2013.01); *A01G 33/00*  
(2013.01); *Y02A 40/88* (2018.01)

(58) **Field of Classification Search**  
CPC ..... C12M 21/02; A01G 31/02  
USPC ..... 435/292.1  
See application file for complete search history.

(71) Applicant:

**SantaMonica**



(72) Inventor:

CA (US)

(\* ) Notice: Subject to any disclaimer, the term of this  
patent is extended or adjusted under 35  
U.S.C. 154(b) by 0 days.

(21) Appl. No.: **15/391,415**

(22) Filed: **Dec. 27, 2016**

(65) **Prior Publication Data**

US 2017/0183614 A1 Jun. 29, 2017

**Related U.S. Application Data**

(60) Provisional application No. 62/366,108, filed on Jul.  
24, 2016, provisional application No. 62/357,987,  
filed on Jul. 2, 2016, provisional application No.  
62/335,617, filed on May 12, 2016, provisional  
application No. 62/330,185, filed on May 1, 2016,  
provisional application No. 62/320,448, filed on Apr.  
8, 2016, provisional application No. 62/316,945, filed  
on Apr. 1, 2016, provisional application No.  
62/316,483, filed on Mar. 31, 2016, provisional  
application No. 62/271,947, filed on Dec. 28, 2015.

(51) **Int. Cl.**

*C12M 1/00* (2006.01)  
*A01G 33/00* (2006.01)

(56) **References Cited**

U.S. PATENT DOCUMENTS

5,097,795 A \* 3/1992 Adey ..... A01K 63/04  
119/226  
2017/0013810 A1 \* 1/2017 Grabell ..... A01G 31/06  
2017/0055474 A1 \* 3/2017 Storey ..... A01G 31/02  
2017/0332568 A1 \* 11/2017 Storey ..... A01G 31/02

OTHER PUBLICATIONS

Carlson, Turbo HF/REV 3 Algae Scrubber from Turbo's Aquatics  
(720p) [video], Jun. 26 2014, retrieved from <https://www.youtube.com/watch?v=BTZMnnU4tiqE> (screenshot attached) (Year: 2014).\*  
Mullins, Algae turf scrubbers-how to remove algae, 2012, retrieved  
from <<https://web.archive.org/web/20140106130358/https://mullinsfarms.com/misc/algae-turf-scrubbers/>> (Year: 2012).\*

\* cited by examiner

*Primary Examiner* — Kevin Joyner

*Assistant Examiner* — Holly Kipouros

(57) **ABSTRACT**

Apparatuses and methods for reducing cost and space  
requirements and increasing ease of cleaning/harvesting of  
algae scrubbers and seaweed cultivators by utilizing illumina-  
tion domes, macroalgal settlement structures, reservoirs  
including overflowing and pole mount, repositionable water  
outlet structures, 3D printed macroalgal attachment materi-  
als, and submersible macroalgal illumination devices.

**20 Claims, 22 Drawing Sheets**

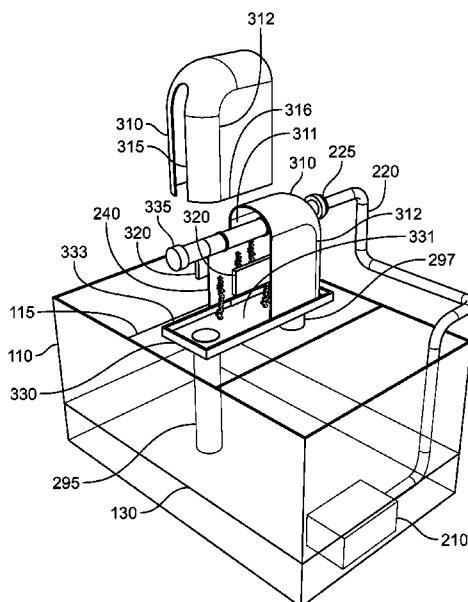

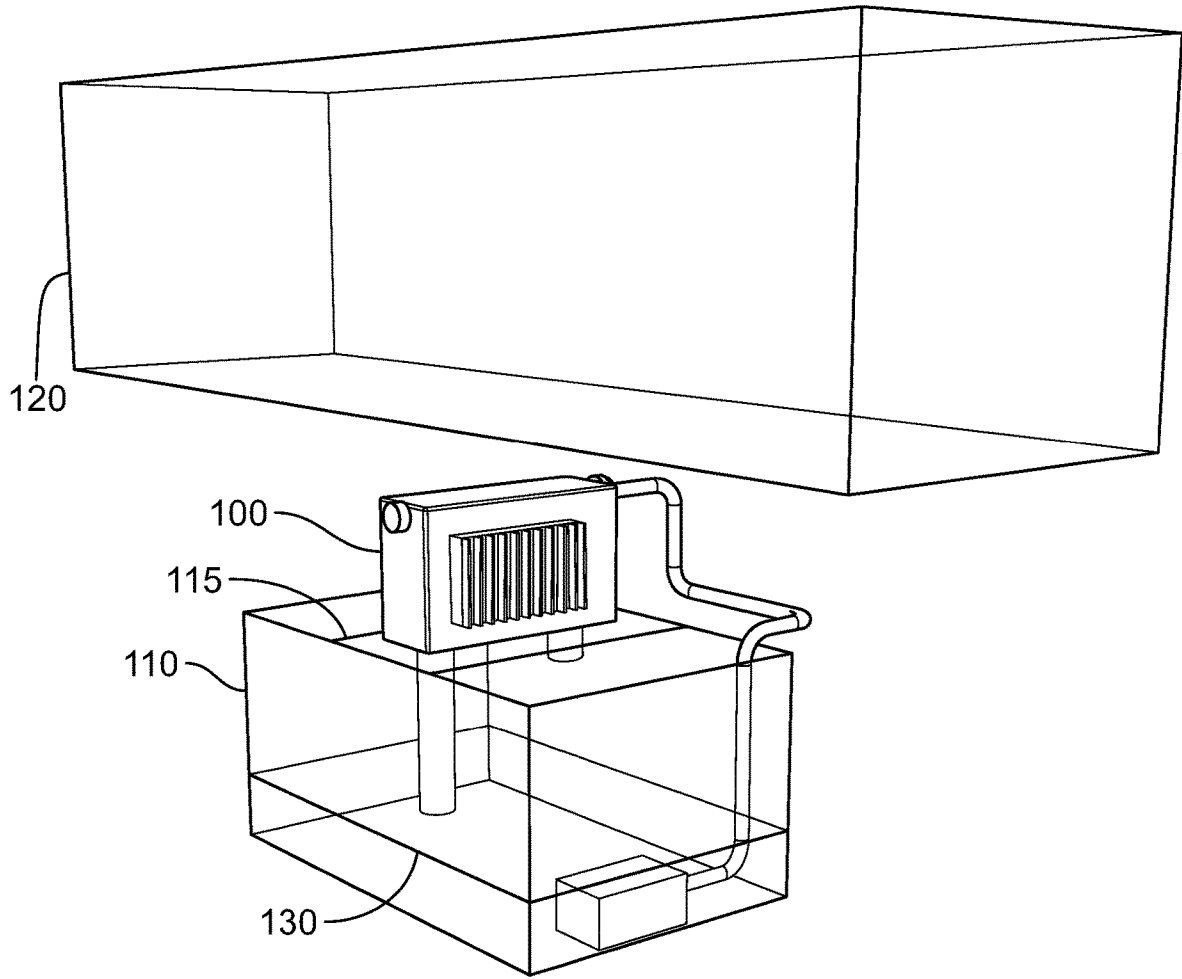

**FIG. 1**  
**(Previous Art)**



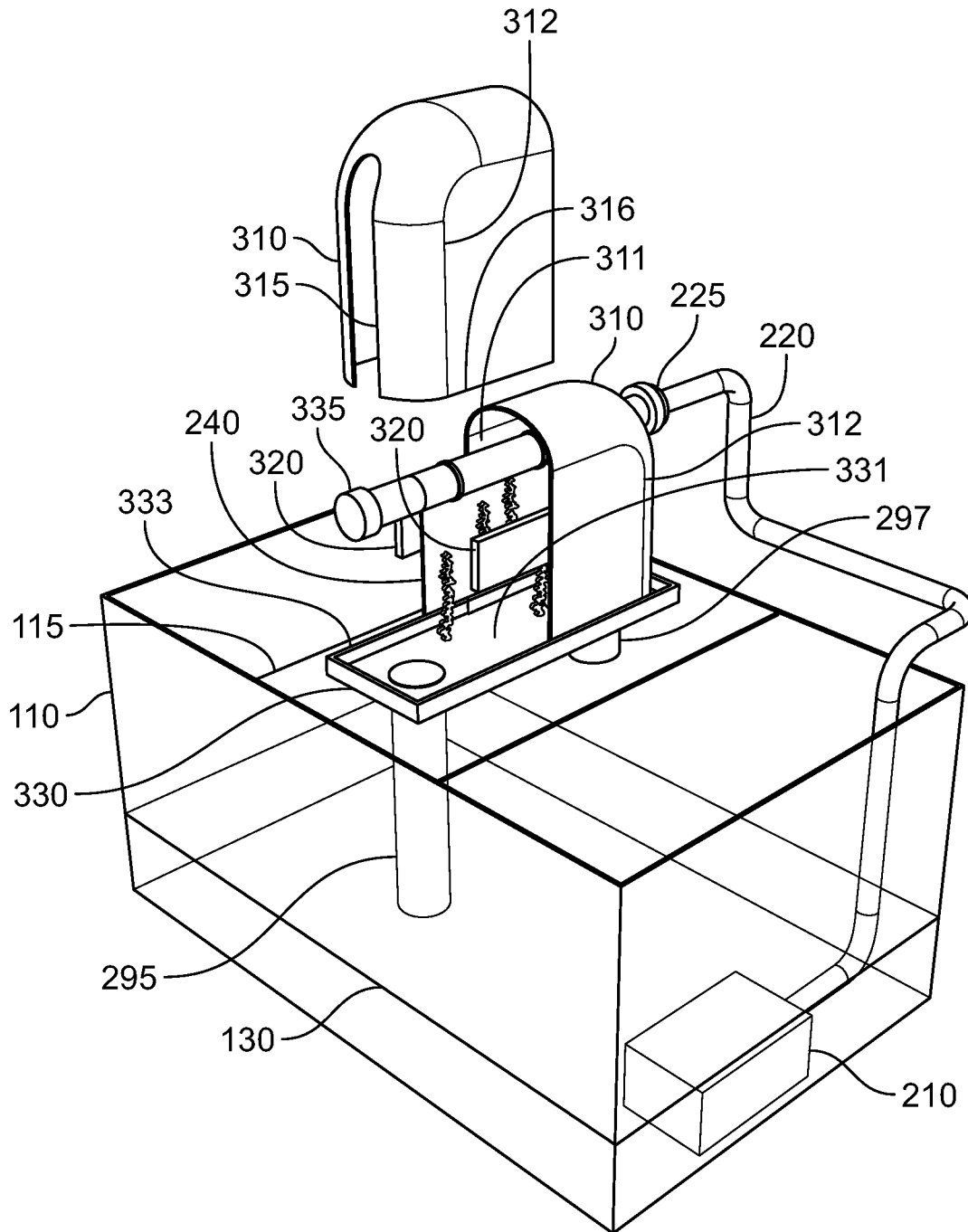

FIG. 3

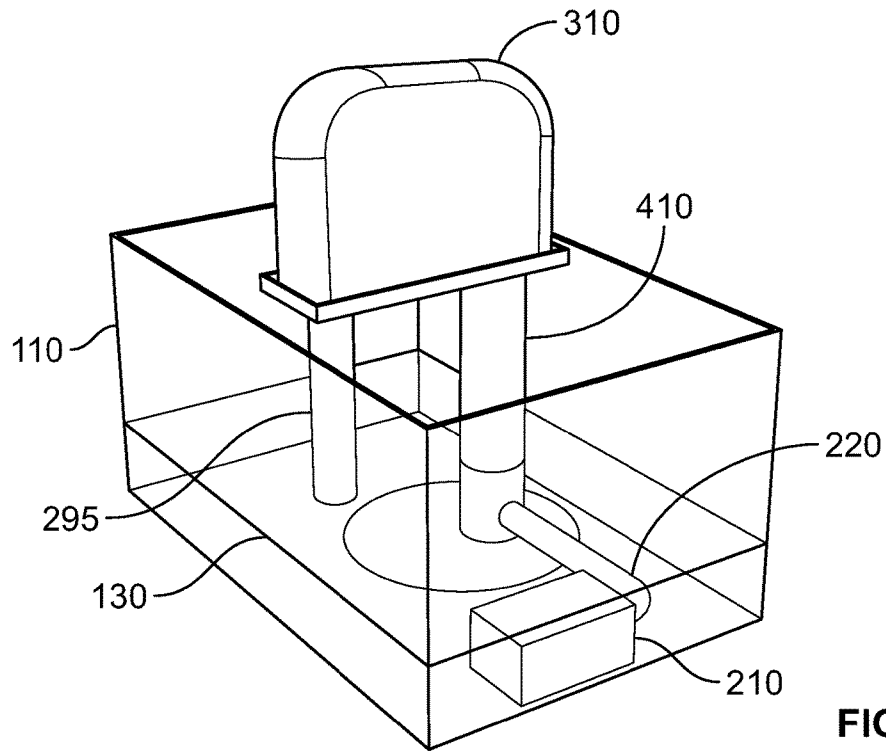

FIG. 4

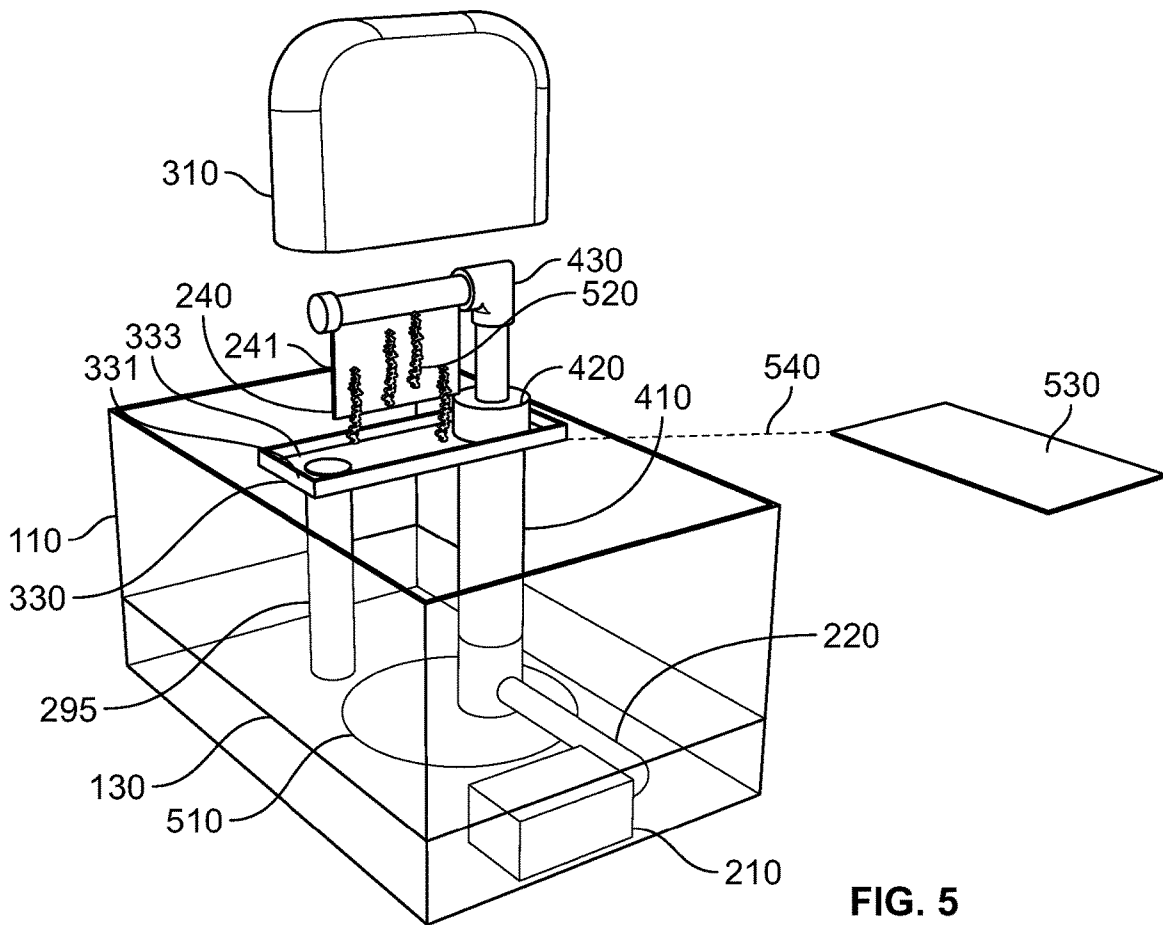

FIG. 5

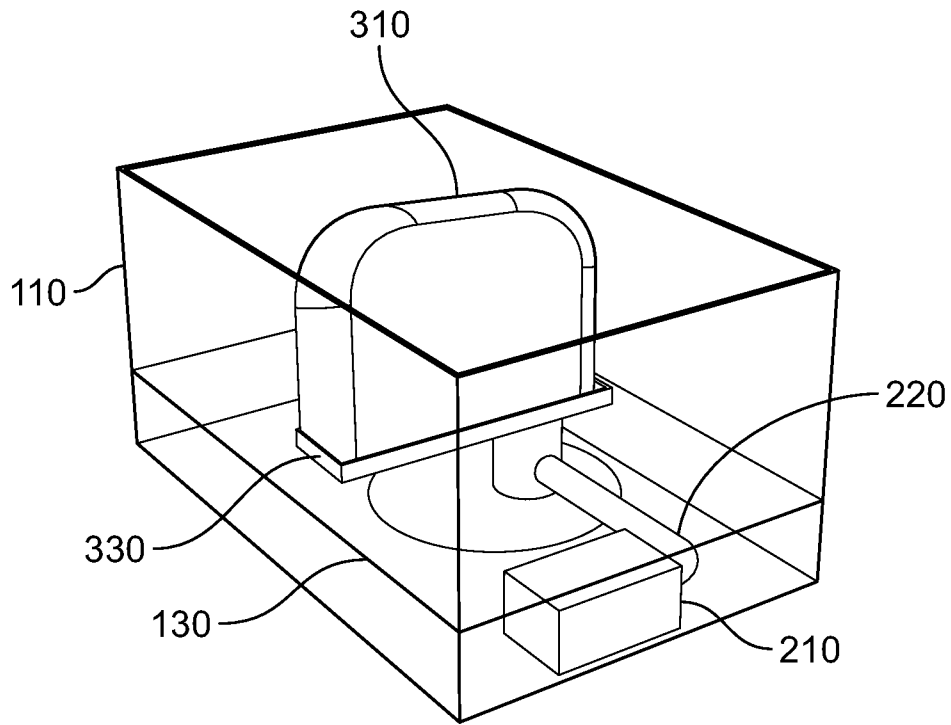

FIG. 6

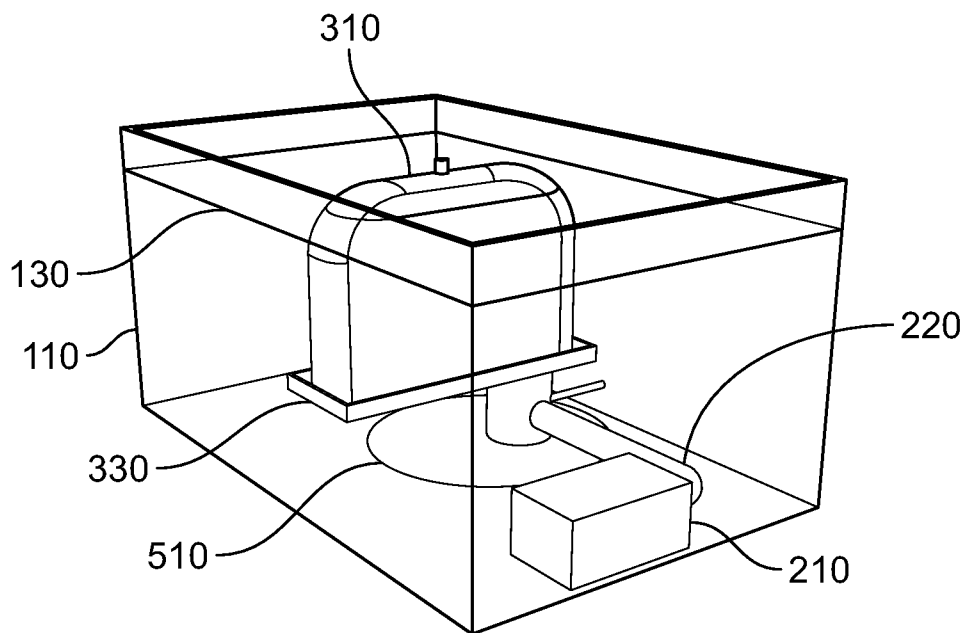

FIG. 7

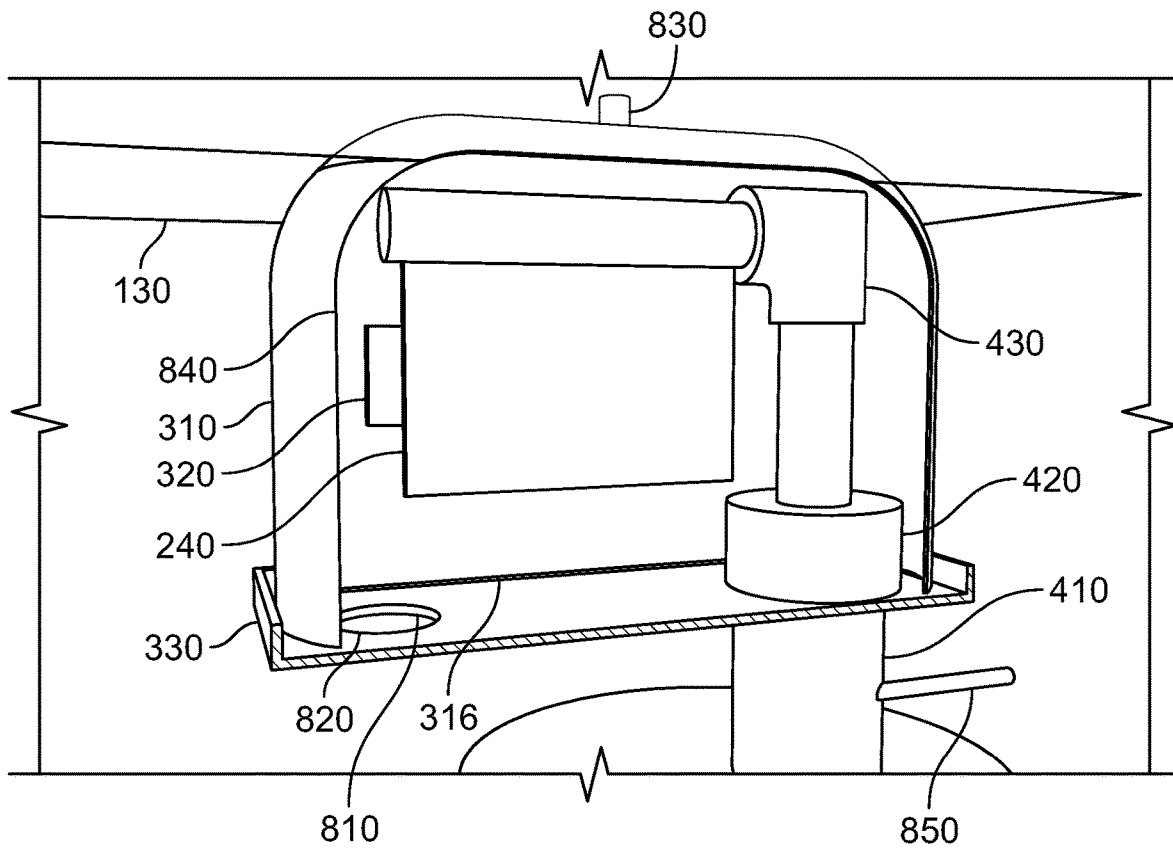

FIG. 8

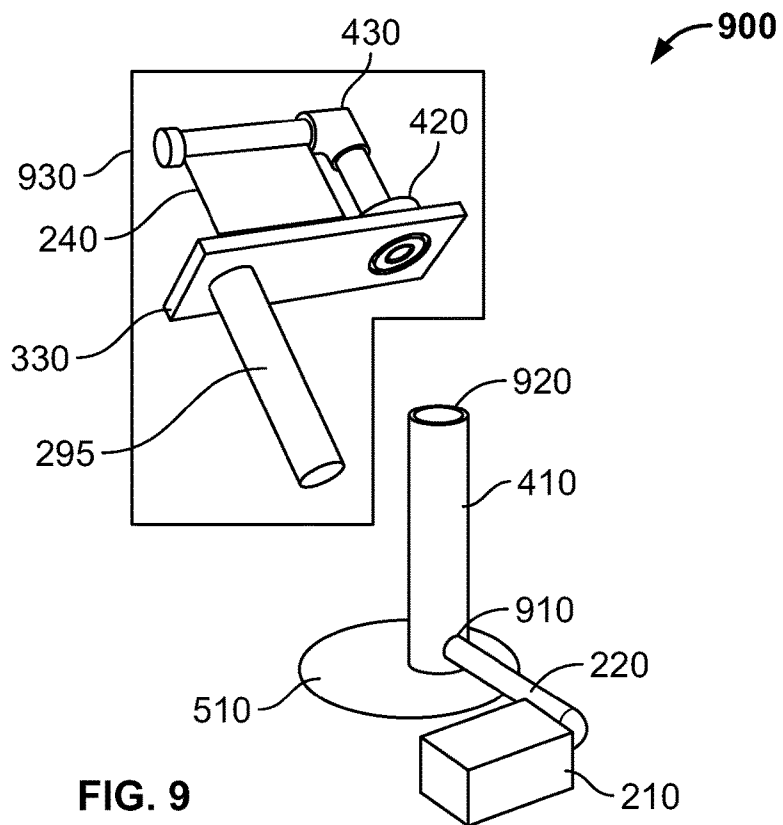
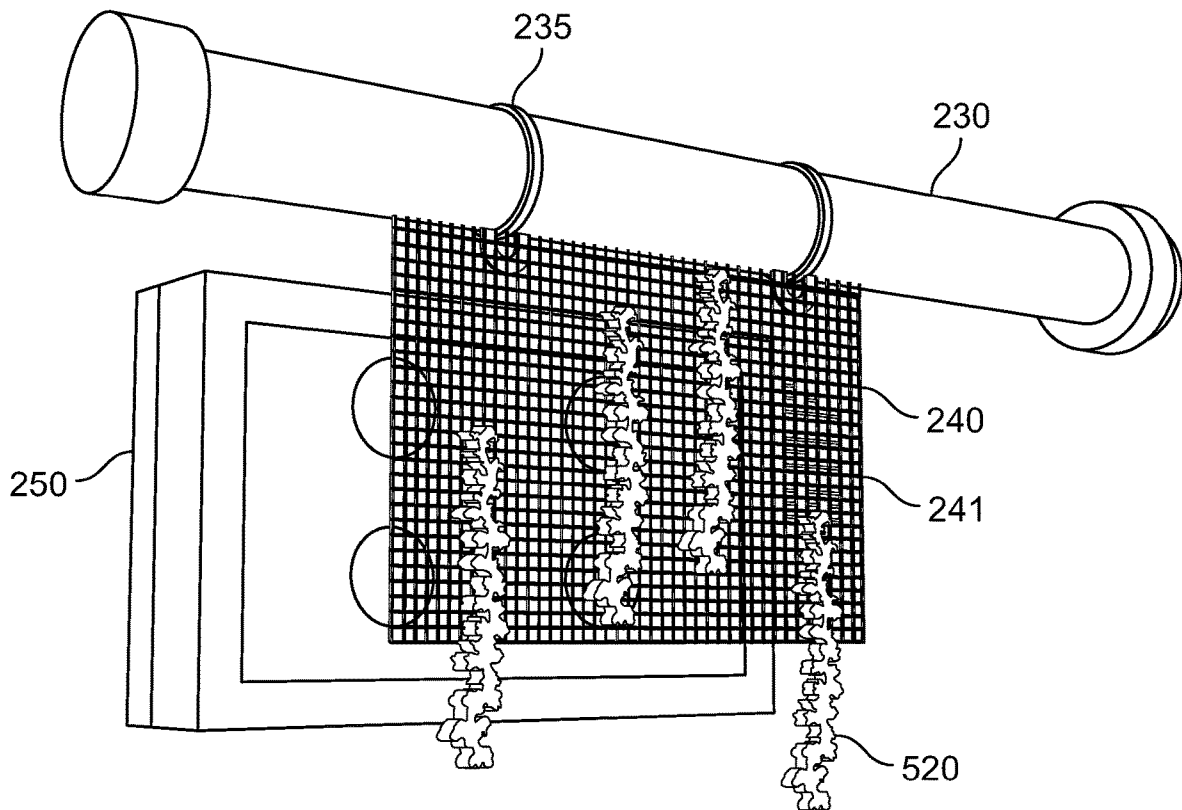

FIG. 9



**FIG. 10**  
**(Previous Art)**



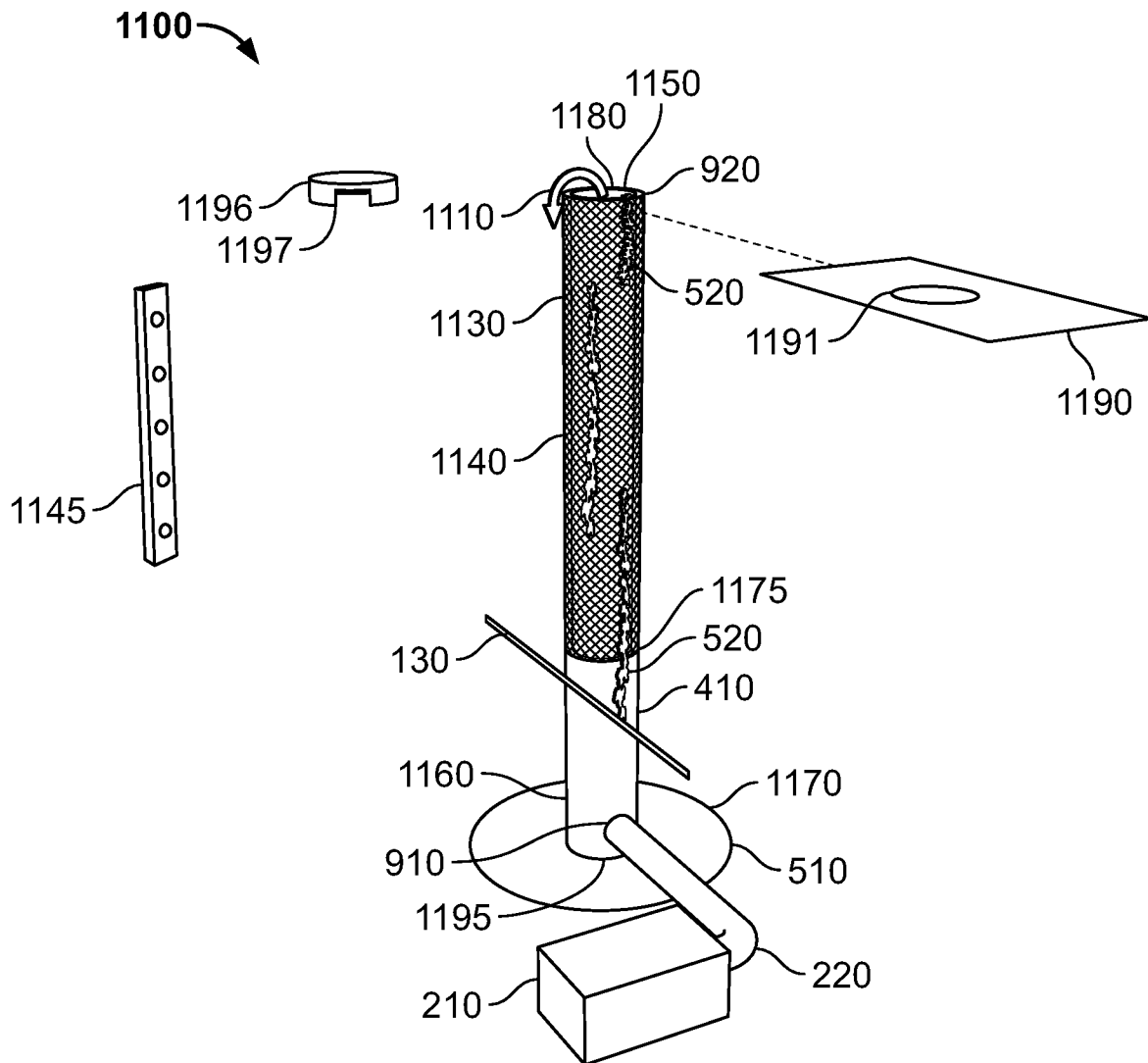

FIG. 11



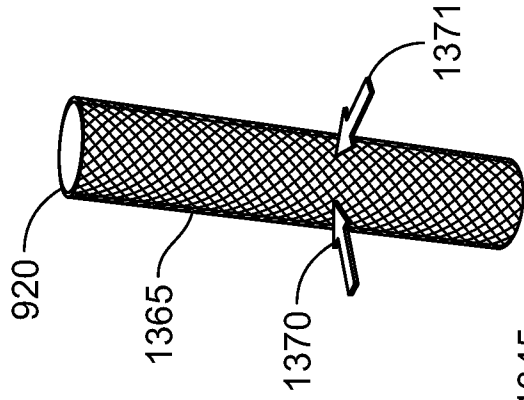

FIG. 13C

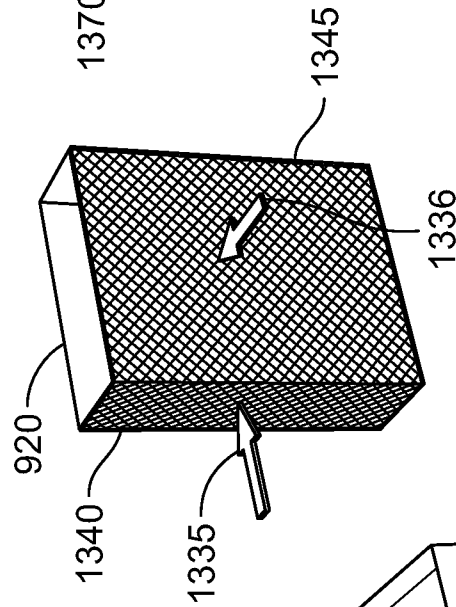

FIG. 13B

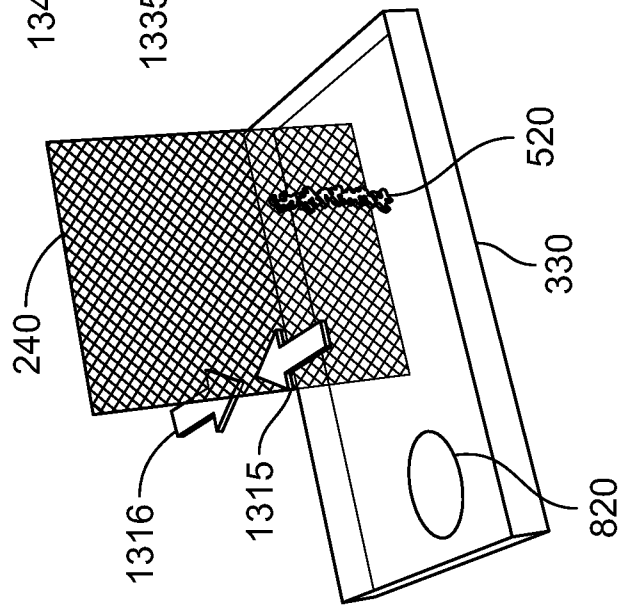

FIG. 13A

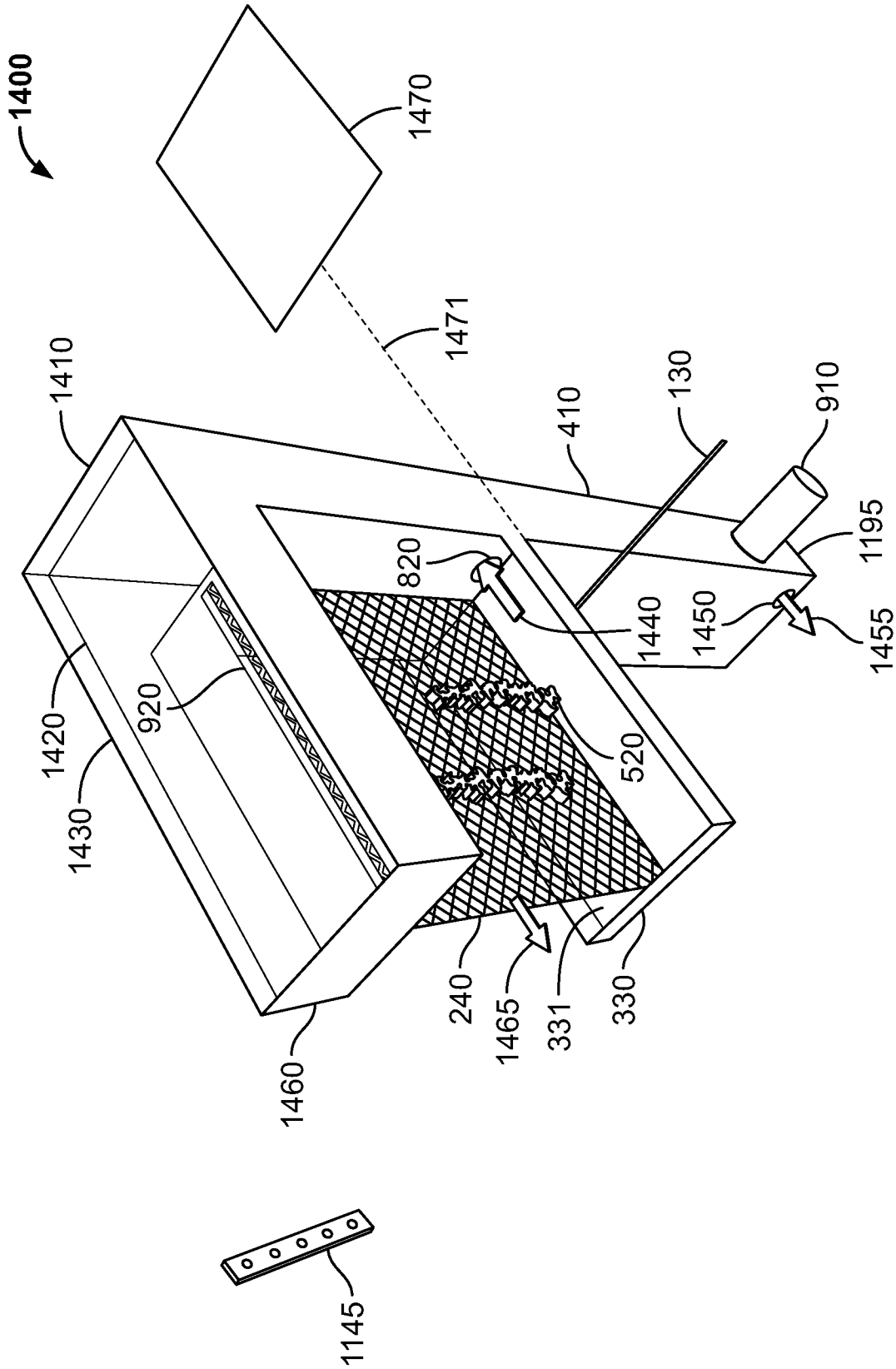

FIG. 14

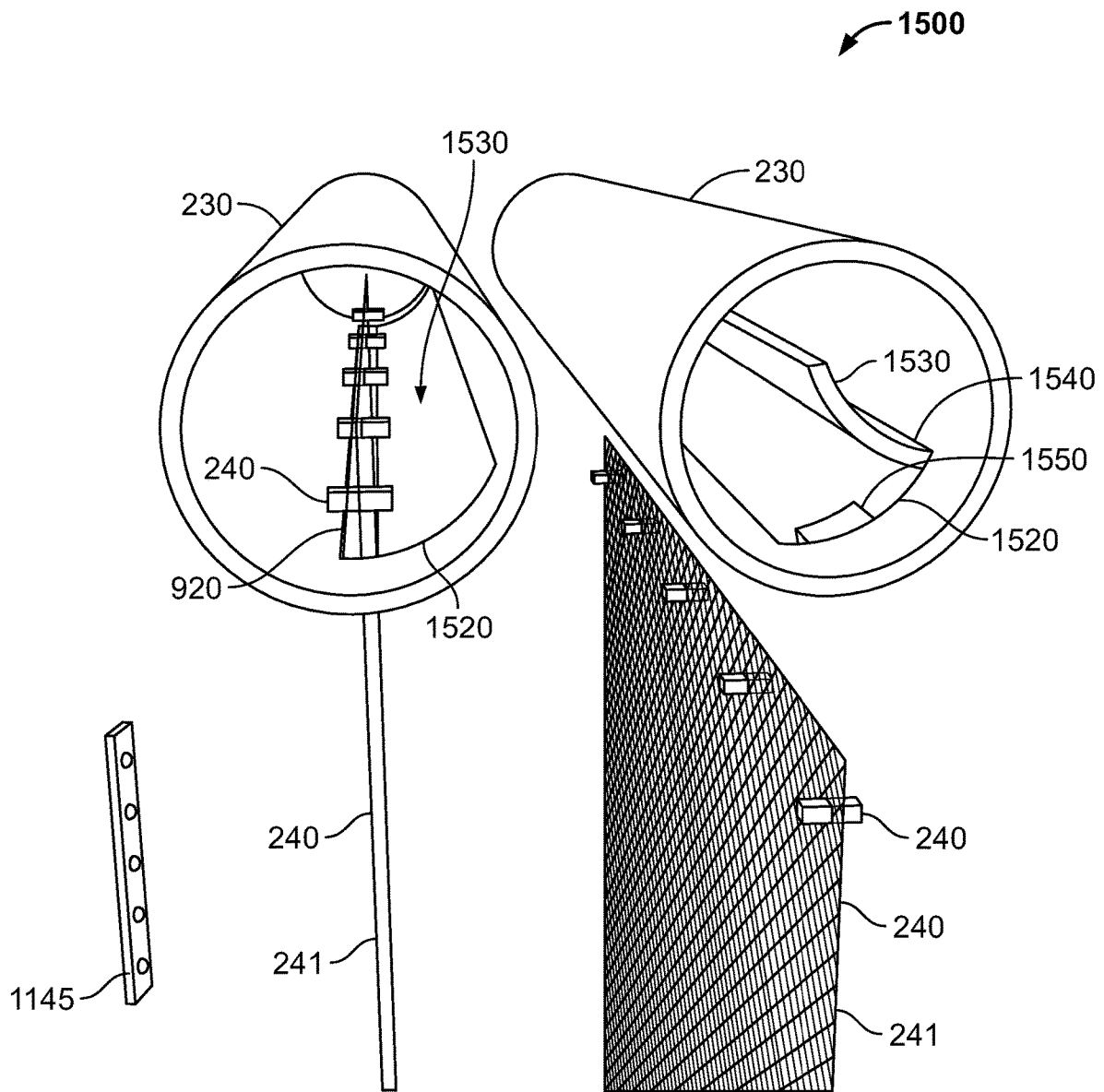

FIG. 15A

FIG. 15B

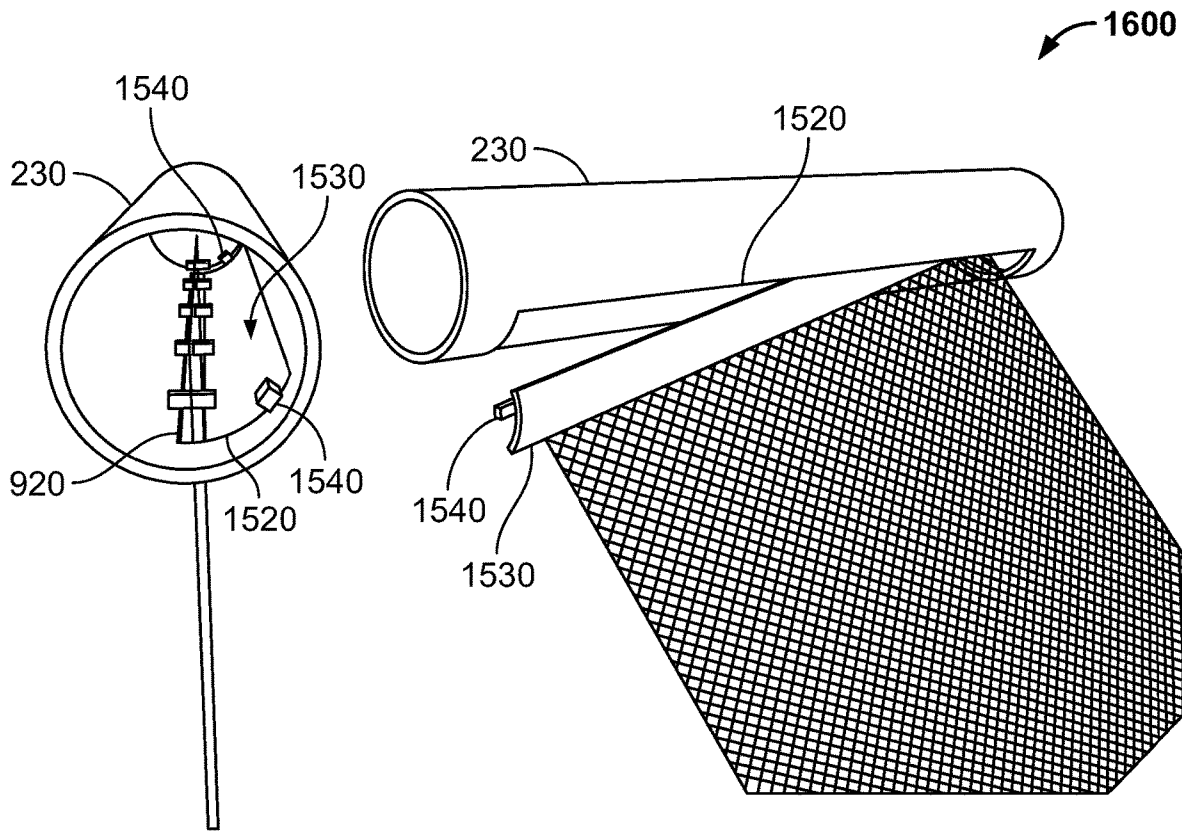

FIG. 16A

FIG. 16B

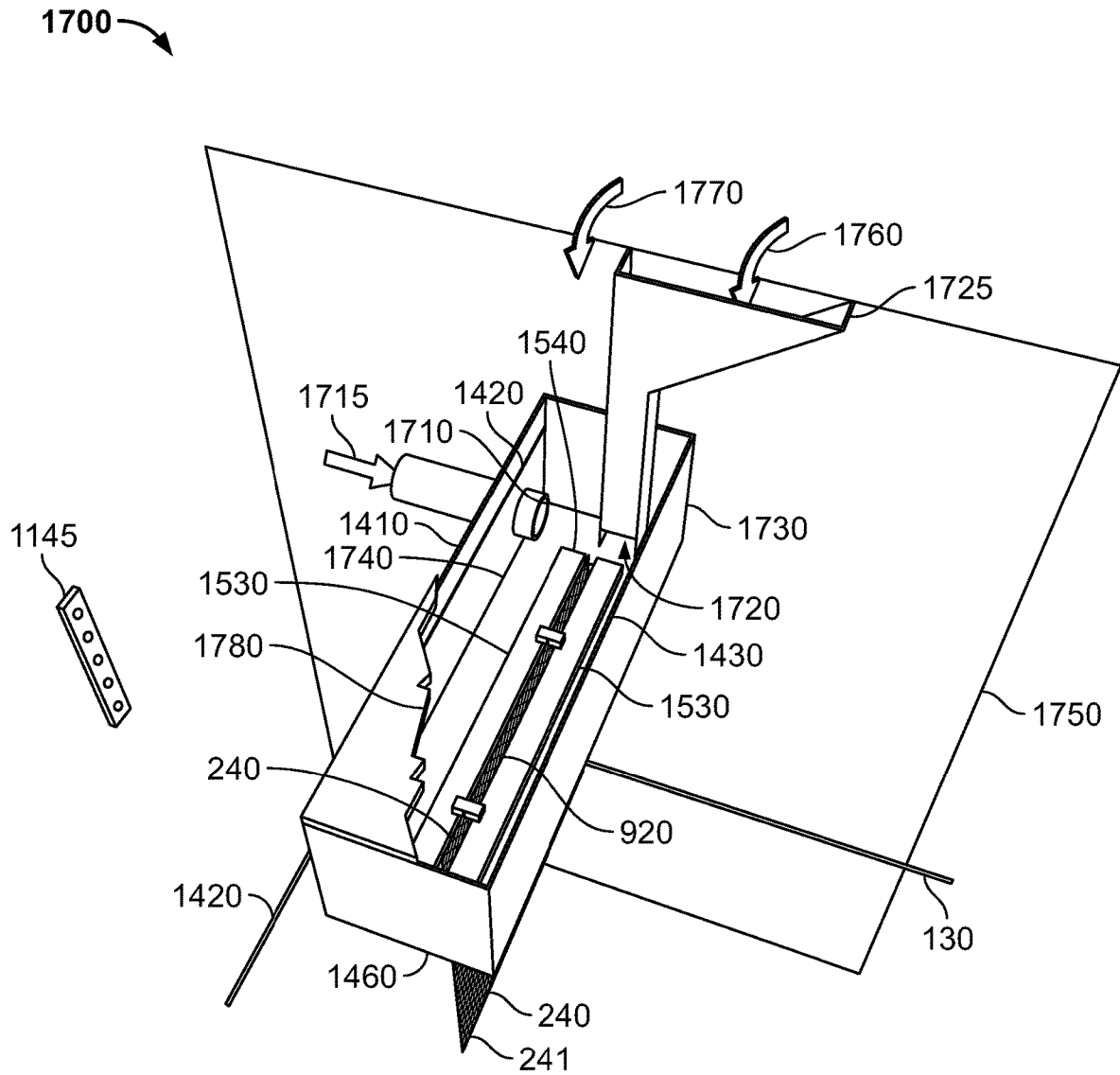

FIG. 17

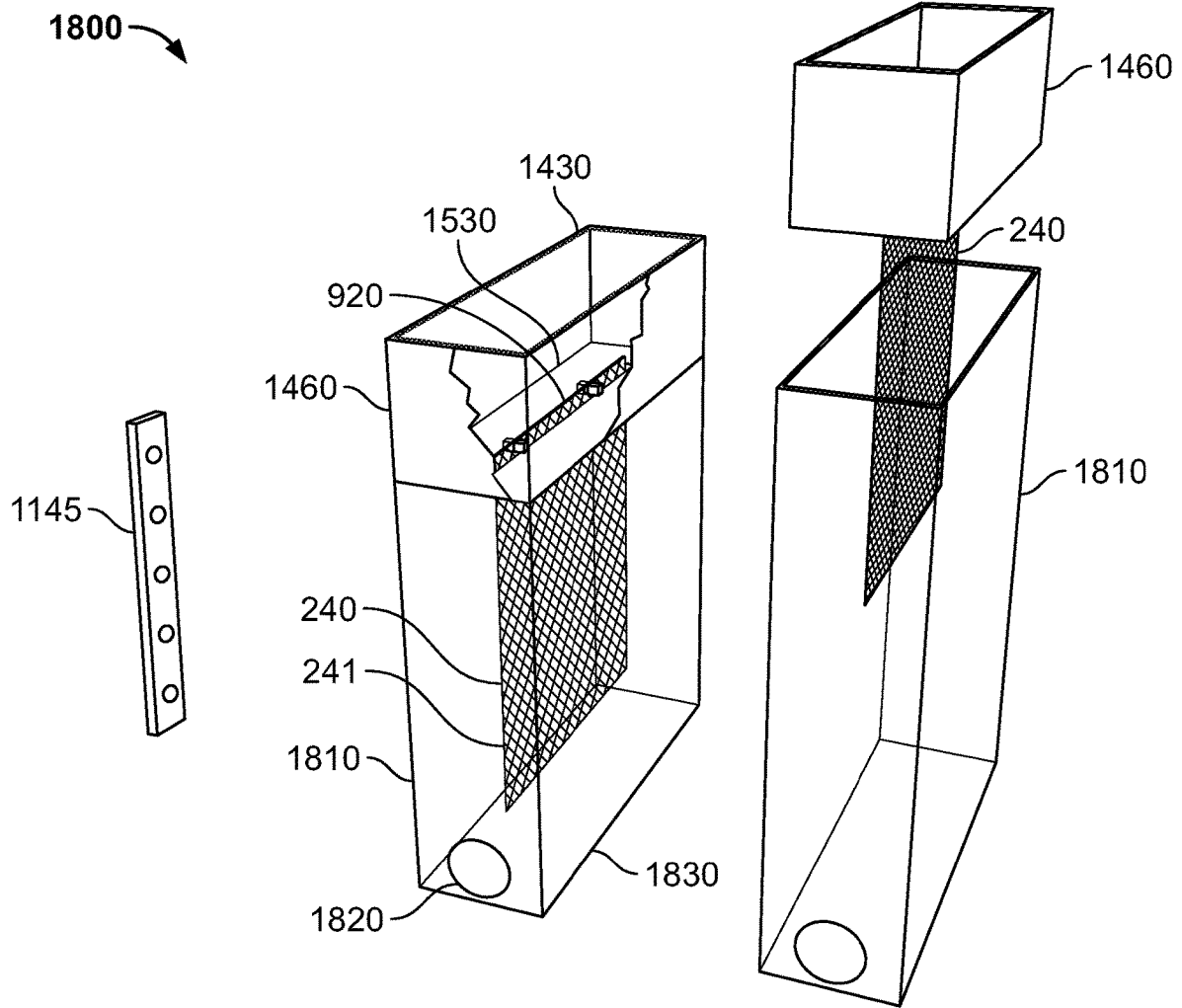
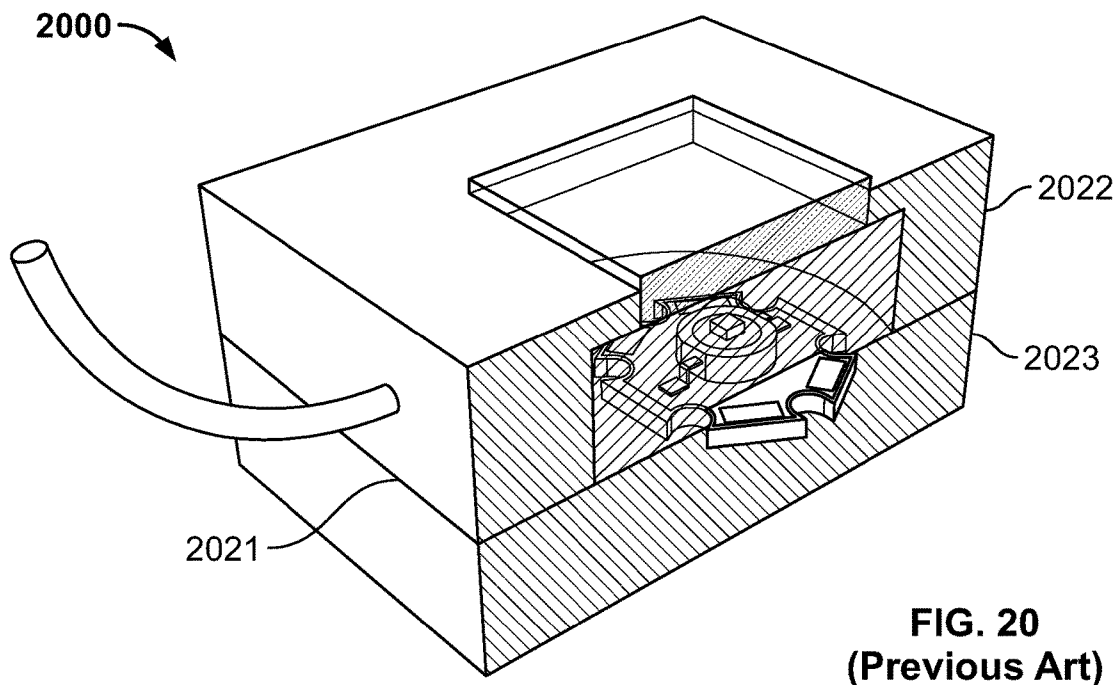
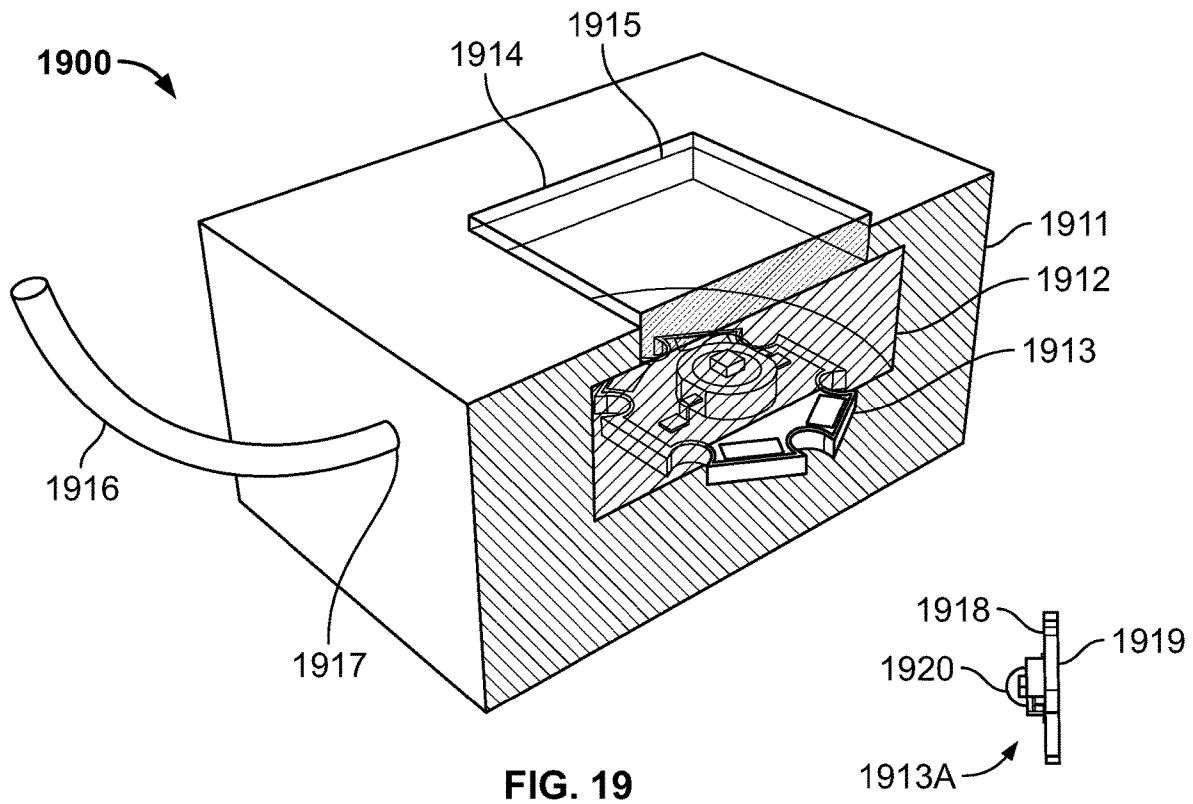

FIG. 18A

FIG. 18B





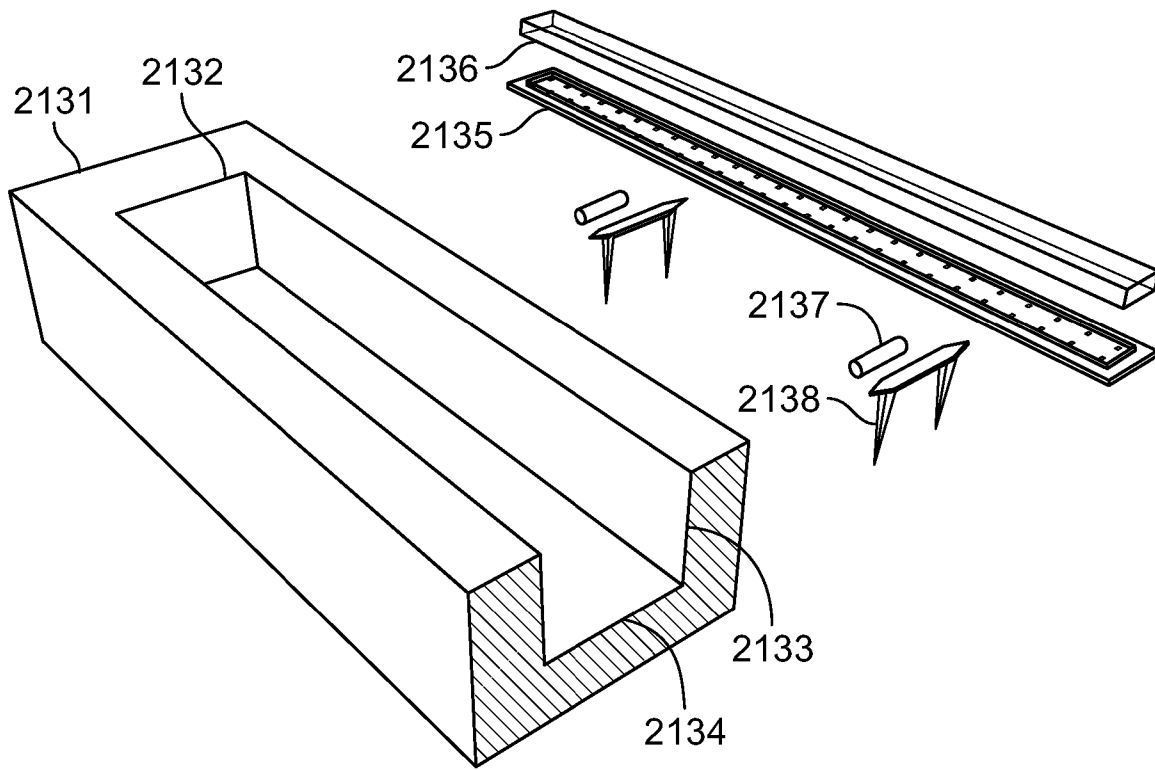

FIG. 21

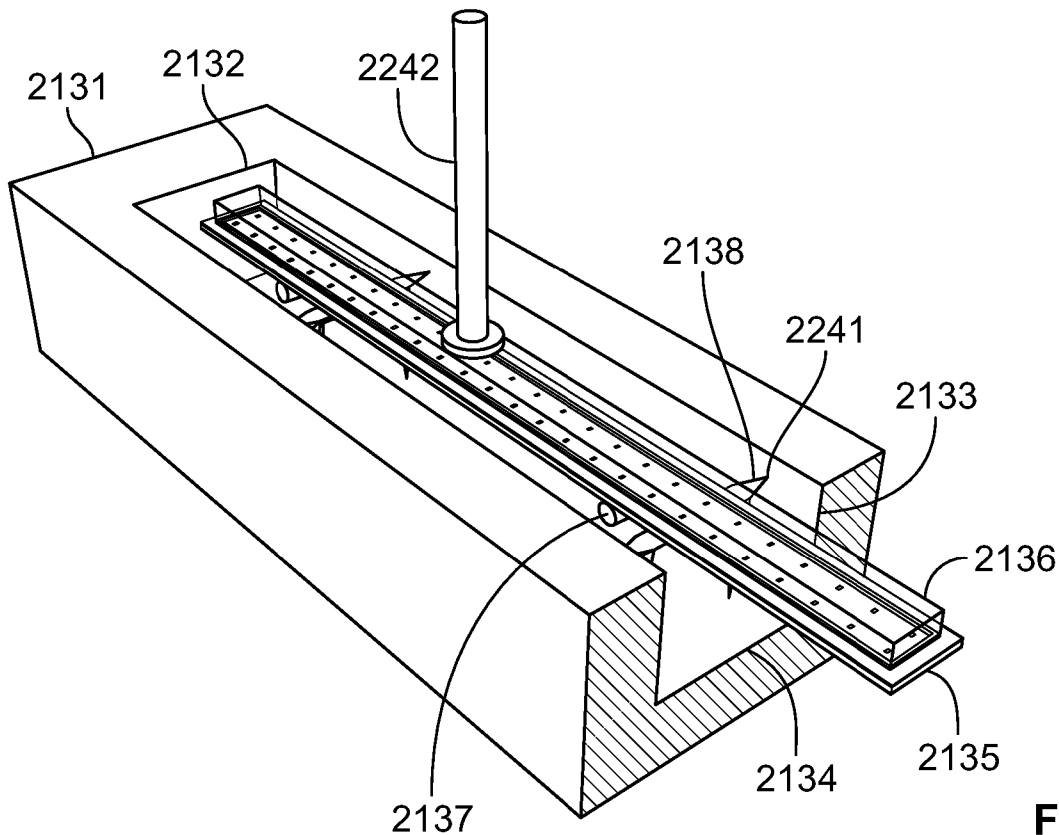

FIG. 22

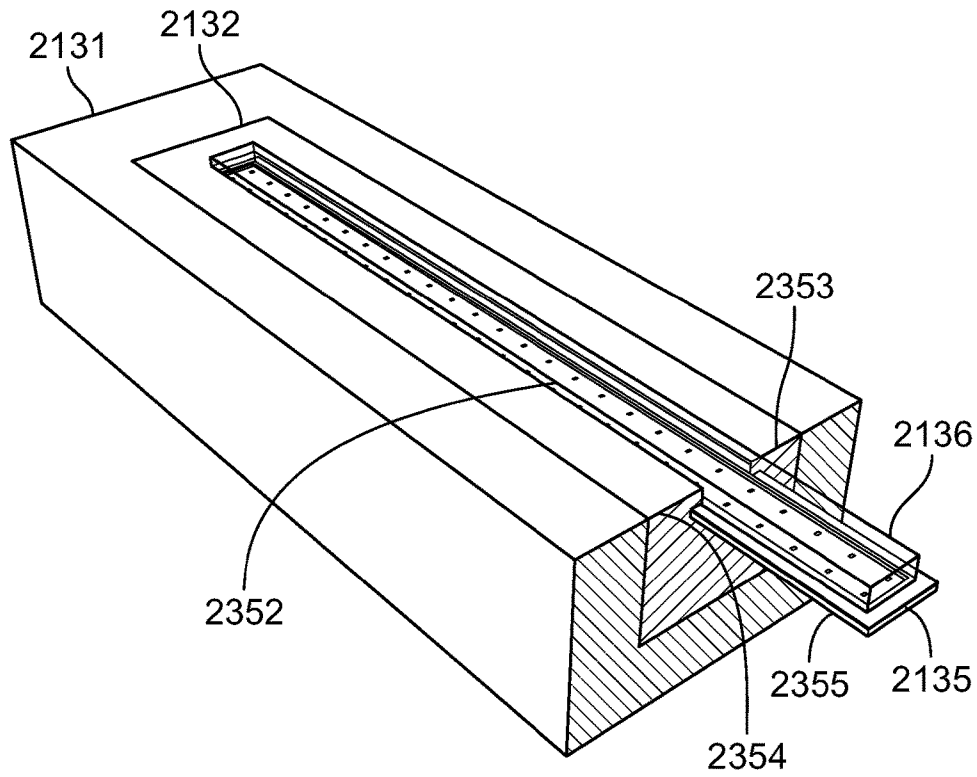

FIG. 23

2400

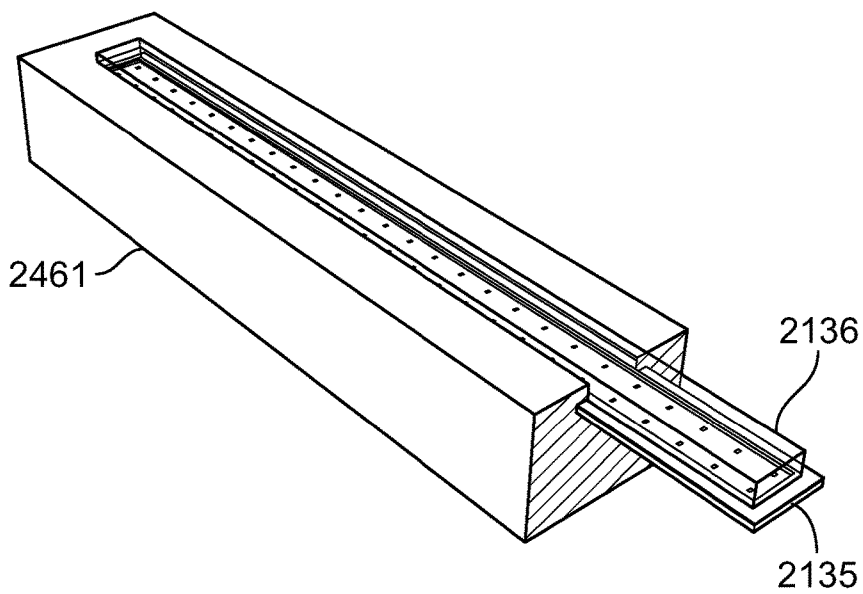

FIG. 24

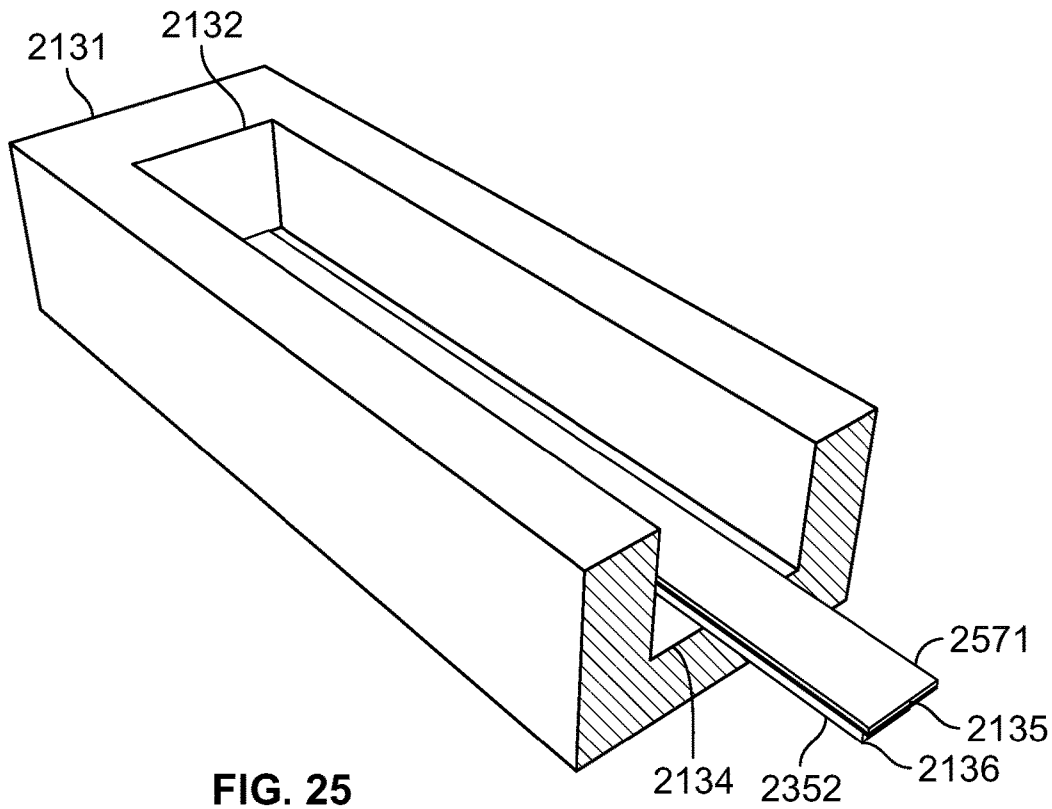

FIG. 25

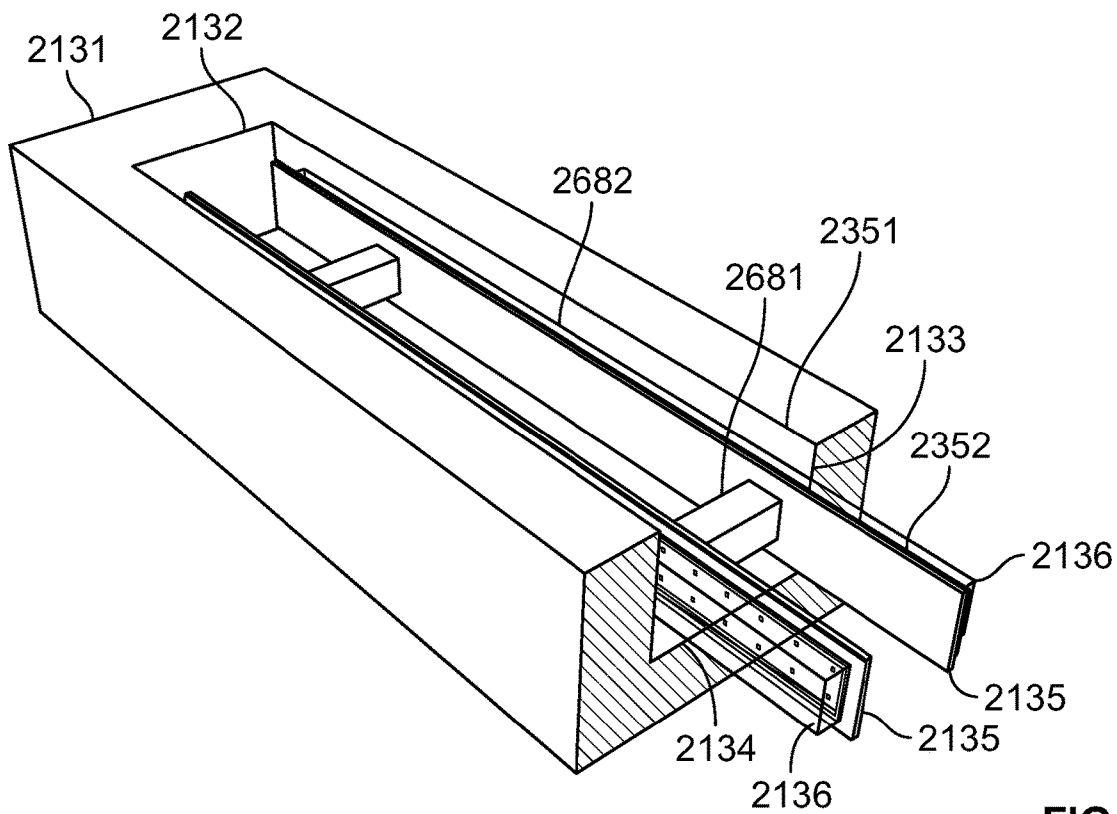

FIG. 26

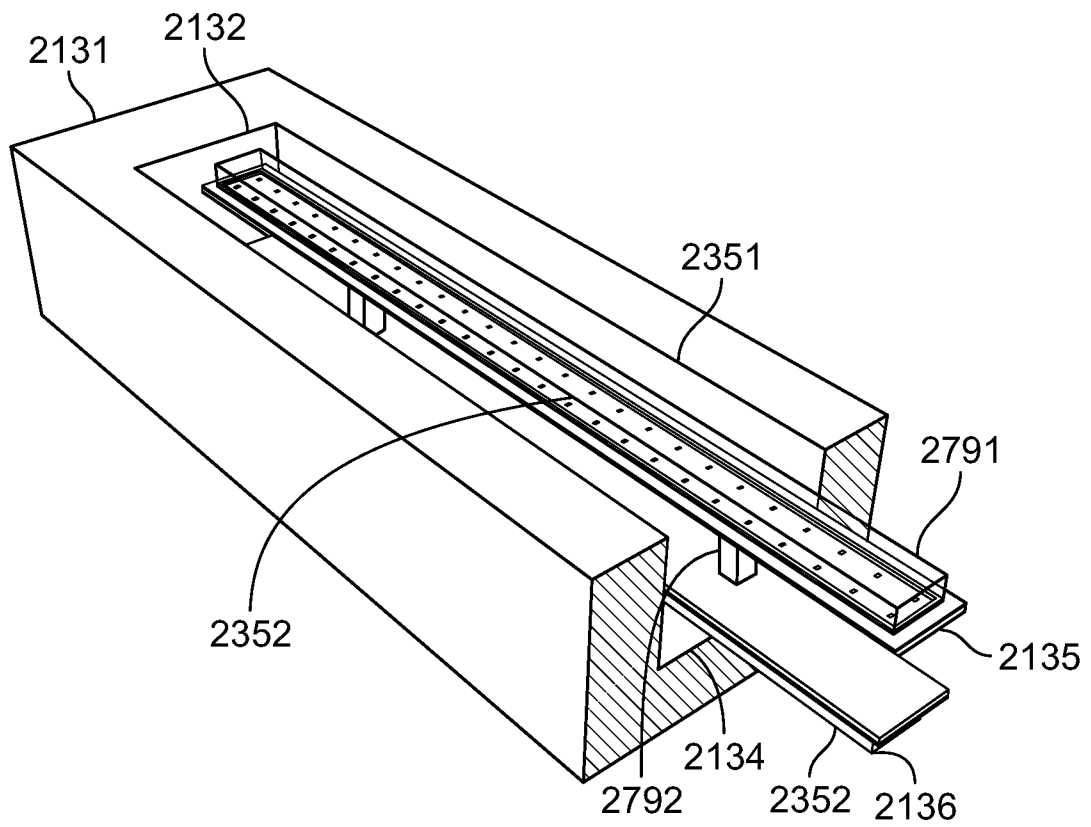

FIG. 27

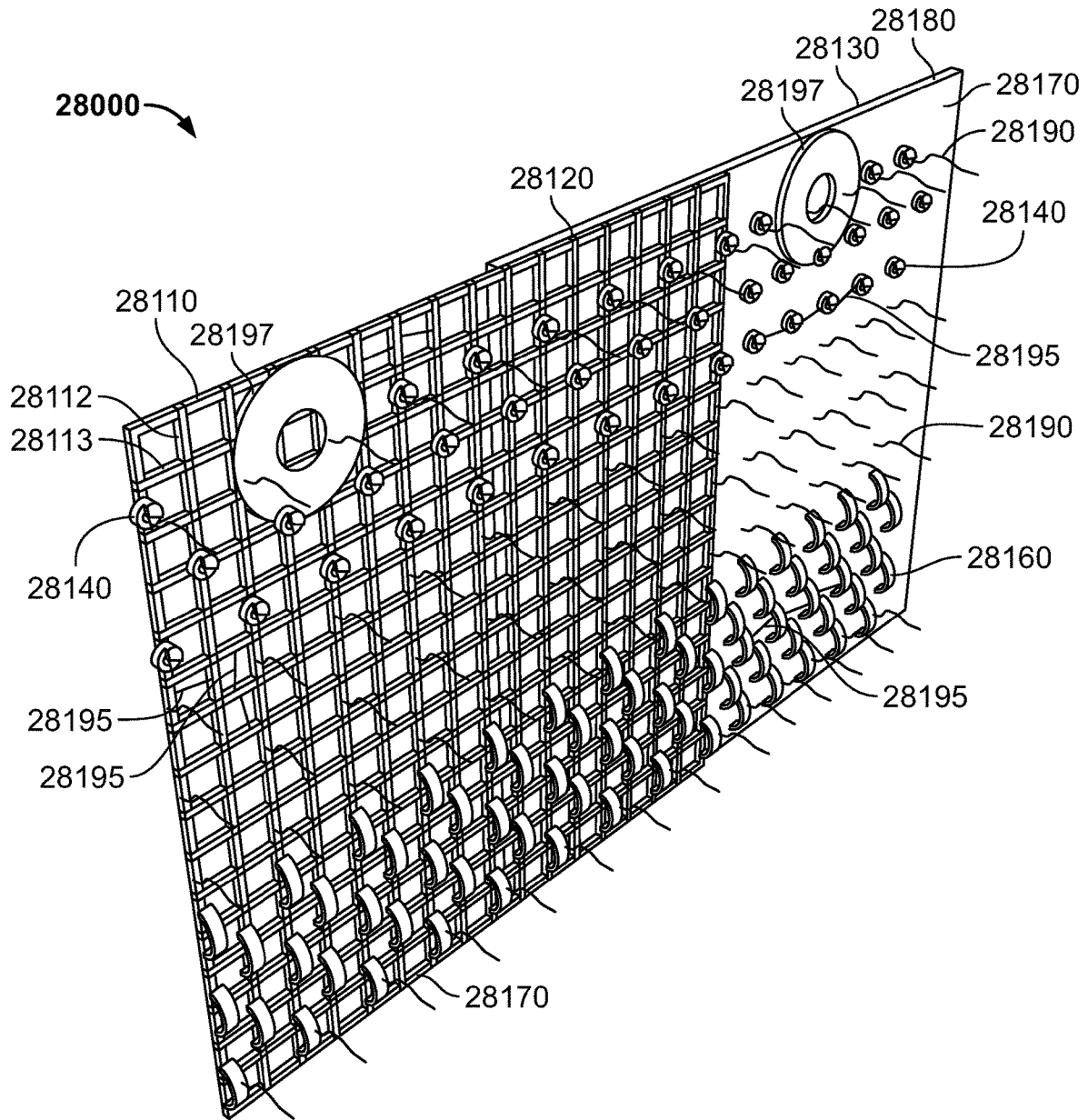

FIG. 28

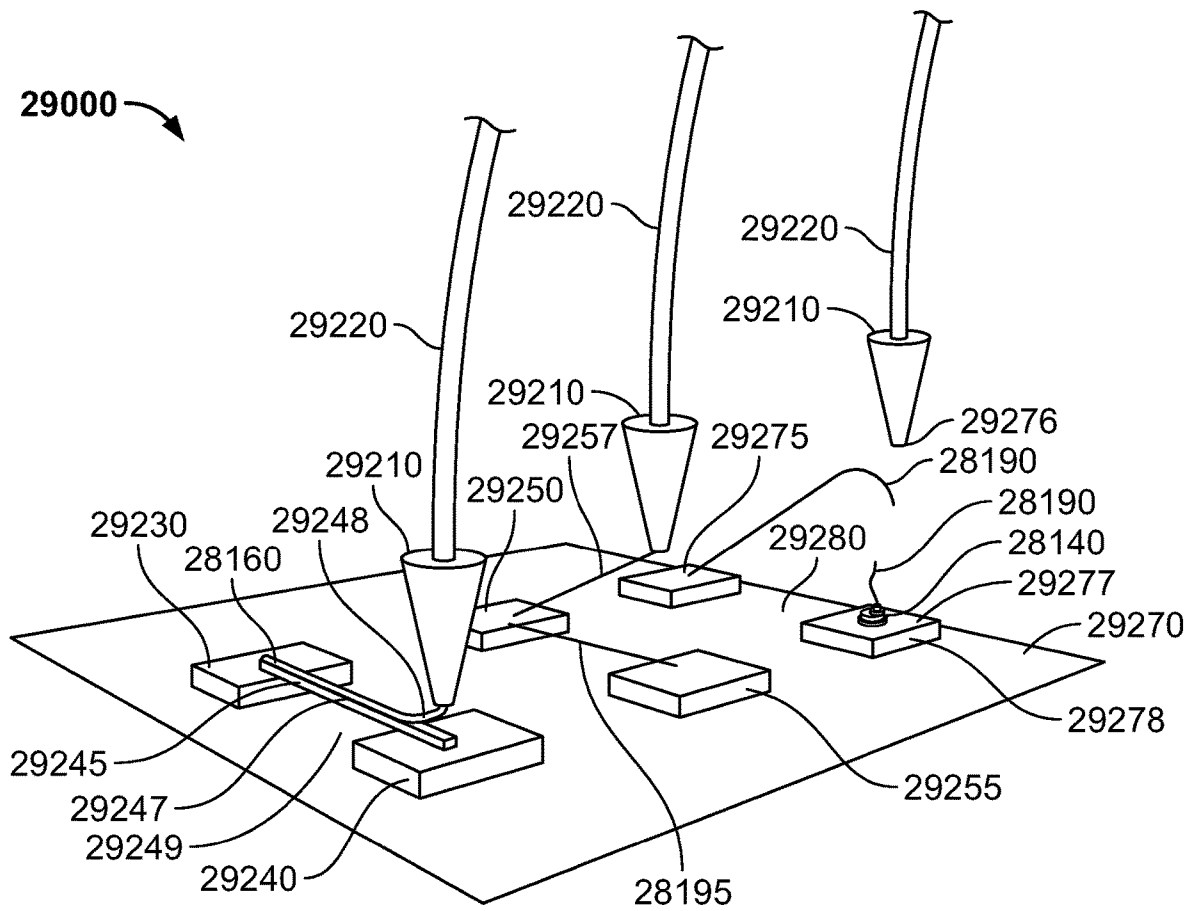

FIG. 29

**ENHANCED MACROALGAL  
PHOTOBIOREACTOR, ALGAE SCRUBBER,  
AND SEAWEED CULTIVATOR METHODS  
AND APPARATUSES—WATER DELIVERY  
STRUCTURES**

CROSS-REFERENCE TO RELATED  
APPLICATIONS

This U.S. utility patent application claims priority to U.S. provisional application 62/271,947 filed Dec. 28, 2015, U.S. provisional application 62/316,483 filed Mar. 31, 2016, U.S. provisional application 62/316,945 filed Apr. 1, 2016, U.S. provisional application 62/320,448 filed Apr. 8, 2016, U.S. provisional application 62/330,185 filed May 1, 2016, U.S. provisional application 62/335,617 filed on May 12, 2016, U.S. provisional application 62/357,987 filed Jul. 2, 2016, and U.S. provisional application 62/366,108 filed Jul. 24, 2016.

FIELD

An embodiment of the invention the generally relates to a mounting system for a waterfall style algae scrubber or waterfall style seaweed cultivator, enabling the construction to be made of fewer materials and components and the operation to be facilitated in a reduced space, an algae scrubber being an apparatus that uses illumination, rough surfaces, and a turbulent air/water interface to purposely grow attached macroalgae on the rough surfaces such that the growth of this macroalgae removes or “scrubs” nutrients out of the water. Another embodiment generally relates to an improved submersible algal growth illumination device. Another embodiment generally relates to 3D printed algal attachment materials. Other embodiments are also described and are divided into pertinent paragraphs with example claims.

BACKGROUND

Many industries such as aquaria, aquaculture, wastewater, and pool and spa rely on “clean” water for their proper operation. In these industries, “clean” is defined as water that is low in nutrients (e.g. Inorganic Nitrate, Inorganic Phosphate, Nitrite, Ammonia, Ammonium, and metals such as Copper). These nutrients cause problems in water such as excessive algae and bacteria growth, and in some cases, poisoning of livestock. In these instances, algae disperse in the water in an uncontrolled manner thereby making algae removal difficult. Thus in these industries there is a desire to remove nutrients and associated algae from the water in order to maintain “clean” water.

Despite the desire to remove nutrients and algae from water for certain applications, many industries rely on the presence of nutrients in the water for success. For example, food and biofuel industries grow algal biomass to produce their final products. This algal biomass requires a constant supply of nutrients to grow. Seaweed cultivators both filter the water of nutrients to provide clean water, and promote controlled growth of algal biomass such that the algae can be easily and efficiently harvested or otherwise removed from the water.

The rapid growth of attached macroalgae in either a filtering or cultivating application requires a turbulent air/water interface to maximize the nutrient transfer into the algae, which in the case of a waterfall is accomplished by gravity pulling a thin layer of water down a rough algal

attachment surface; this requires the waterfall to be above a surrounding water surface level. A support structure for previous art waterfalls was needed to suspend the algae scrubber device above the surrounding water surface level; the support and waterfall were large and heavy because of the jolting movement of the water supply source tubing and the weight of the algal growth that was pulling downwards. Furthermore, illumination devices were in close proximity to algal attachment surfaces and had to be water resistant and heat sinked, which made them heavy and bulky also and thus requiring a more substantial frame or support. This added frame and bulk usually sat on a shelf in a sump beneath an aquarium, and provided limited access to the algae attachment surface for observation or cleaning/harvesting. Further, the entire structure of the waterfall, attached illumination devices, and water supply tubing usually took the majority of the open air space above the sump and therefore limited or eliminated access to the water below it. Thus there is a need for a simpler and space saving mounting and water delivery system for waterfall algae scrubbers and waterfall seaweed cultivators.

The illumination that drives the photosynthetic growth of the seaweed can be supplied by natural or artificial means. Light emitting diodes (LEDs) and similar artificial illumination emitters are commonly used, however they produce heat and require protection from water, especially saltwater. Common “plant-grow” hydroponic illumination units are readily available which are water resistant and even waterproof, however they usually are constructed with at least part of the enclosure being made of metal or a partially metallic material. Other waterproof illumination devices such as used for pools or boating also seal the illumination emitter from the water, but similar to hydroponic illumination units they do not protect the water itself from the metals, nor do they need to. These metals, if in continuous contact with saltwater, may slightly or rapidly corrode, and may cause serious damage to reef aquaria invertebrates. Even stainless steel is preferred to not be used. Invertebrates are very susceptible to small amounts of certain metals, and even the slightest trace of copper will kill them. Thus there is a need for a submersible non-metallic illumination device which is compact and lightweight in order to reduce the size and complexity of waterfall algae scrubbers.

For both filtration and cultivation, attachment of the macroalgae to solid surfaces is needed, and the surfaces should be rough and porous to encourage this attachment. Current rough attachment surfaces however are complex to manufacture or laborious to make manually. Thus, there is a need for algae scrubber and seaweed cultivator macroalgal attachment materials which are lower in cost and easier to manufacture.

SUMMARY

Applicant’s SURF, HOG, and DROP Scrubbers® are examples of algae scrubber devices which operate using an upflowing gas bubble method, and applicant’s RAIN™ algae scrubbers operates using a waterfall method. An embodiment of the current disclosure is directed towards waterfalls for supporting macroalgal attachment material and supplying water to a macroalgal attachment surface, and comprises a macroalgal attachment material that defines a macroalgal attachment surface; a reservoir structure that defines a reservoir top opening, a reservoir compartment and water outlet; and a macroalgal attachment material positioning mechanism to position the macroalgal attachment material substantially beneath the water outlet and to align the



macroalgal attachment surface such that water flowing out of the water outlet contacts the macroalgal attachment surface.

Another embodiment of the current disclosure is for releasably supporting macroalgal attachment material and supplying water to a macroalgal attachment surface, and comprises a macroalgal attachment material defining a macroalgal attachment surface; a water delivery structure defining a water outlet border; a water outlet structure movable from a first position to a second position and which defines a portion of a water outlet when in the first position; and a positioning means which positions the water outlet structure in the first position abutting the water outlet border such that the macroalgal attachment material is secured substantially below the water outlet structure and water from the water outlet contacts the macroalgal attachment surface and further enables movement of the water outlet structure to the second position such that the macroalgal attachment material may be removed from the water delivery structure.

Another embodiment of the current disclosure is for supporting a structure which supports macroalgal attachment material and supplies water to a macroalgal attachment surface, and comprises a macroalgal attachment material defining a macroalgal attachment surface; a macroalgal settlement structure defining a macroalgal settlement surface; a water delivery structure which intersects a plane of the macroalgal settlement surface; a positioning mechanism to position the macroalgal attachment material such that the macroalgal attachment surface receives water from the water delivery structure; and an attachment mechanism to couple the macroalgal settlement structure to the water delivery structure and to align the macroalgal settlement surface such that macroalgae is enabled to travel from the macroalgal attachment surface to the macroalgal settlement surface.

Another embodiment of the current disclosure is for utilizing as much of a structure as possible in an overflowing manor, and comprises a reservoir structure defining a reservoir compartment, a water inlet, a water outlet; a macroalgal attachment material defining a macroalgal attachment surface; and an attachment mechanism to position the macroalgal attachment material such that water flowing out of the water outlet overflows down an external surface of the reservoir structure and makes contact with the macroalgal attachment surface.

Another embodiment of the current disclosure is for enclosing a waterfall algae scrubber or seaweed cultivator, and comprises an enclosure structure movable from a first position to a second position, the first position enclosing an algal attachment surface such that illumination from inside the structure is substantially prevented from traveling outside the structure, and the second position such that access to the algal attachment surface is substantially increased relative to the first position.

Another embodiment of the current disclosure is for illuminating macroalgal attachment surfaces under or above water, and comprises an illumination emitter, a lens, and an overmold that is substantially thermally conductive, substantially electrically non-conductive, and substantially non-metallic, the overmold to position the lens to be in optical communication with the illumination emitter and to enable illumination and heat from the illumination emitter to travel to surrounding ambient air or water such that the apparatus can operate in ambient air or submerged in water without moisture or heat damage to the illumination emitter.

Another embodiment of the current disclosure is for 3D printed macroalgal attachment surfaces, and includes a macroalgal attachment material comprising a first sheet of

polymer having a top surface and a bottom surface, with a plurality of lumps positioned on the top surface whereby the lumps provide attachment surfaces for freshwater and salt-water macroalgae. The lumps extend 1-5 mm out from the top surface, and are 1-5 mm in diameter each. Each lump has a hairline thread extending from it, and all hairline threads are substantially in a uniform direction and non-touching so as to allow comb-harvesting, or are in a non-uniform direction and are touching so as to enable slime algae to attach better. The material is PETG, and is attached to a second sheet of material so as to have lumps on both sides of the sheet for freshwater and saltwater macroalgae to attach to. The sheet of material also includes one or more grommets for attachment to a stationary object, and the grommets themselves have lumps on them so as to maximize algal attachment.

#### BRIEF DESCRIPTION OF THE DRAWINGS

The embodiments of the invention are illustrated by way of example and not by way of limitation in the figures of the accompanying drawings, in which like references indicate similar elements. It should be noted that references to “an” or “one” embodiment of the invention in this disclosure are not necessarily to the same embodiment, and they mean at least one.

FIG. 1 shows a perspective view of a previous art waterfall algae scrubber designed in 2008, setting on a shelf in a sump beneath an aquarium.

FIG. 2 shows a perspective view of the previous art waterfall algae scrubber of FIG. 1, exploded.

FIG. 3 shows a perspective view of an embodiment of the current invention utilizing an illumination dome.

FIG. 4 shows a perspective view of an embodiment of the current invention utilizing an illumination dome and a pole mount reservoir.

FIG. 5 shows a perspective view of the embodiment of FIG. 4 with the illumination dome lifted upwards.

FIG. 6 shows a perspective view of the embodiment of FIG. 4 lowered to operate at the water level in the sump.

FIG. 7 shows a perspective view of an embodiment of the current invention utilizing an illumination dome for submerged waterfall operation.

FIG. 8 shows a perspective cutaway underwater view of the embodiment of FIG. 7.

FIG. 9 shows a perspective view of the embodiment of FIG. 5 separated from its pole mount reservoir.

FIG. 10 shows a perspective view of components of a previous art waterfall algae scrubber designed in the year 2008.

FIG. 11 shows a perspective view of a pole mount reservoir overflow embodiment of the current invention.

FIG. 12 shows a perspective view of another pole mount reservoir overflow embodiment of the current invention.

FIG. 13A shows a perspective view of a 2-sided macroalgal attachment surface, and perpendicular access.

FIG. 13B shows a perspective view of a 1-sided macroalgal attachment surface, and perpendicular access.

FIG. 13C shows a perspective view of another 2-sided macroalgal attachment surface, and perpendicular access.

FIG. 14 shows a perspective view of a pole mount reservoir-fed embodiment of the current invention.

FIG. 15A shows a perspective view of a screen-release embodiment in a water pipe, of the current invention.

FIG. 15B shows a perspective view of the screen-release embodiment of FIG. 15A, with the screen removed.

5

FIG. 16A shows a perspective view of another screen-release embodiment in a water pipe, of the current invention.

FIG. 16B shows a perspective view of the screen-release embodiment of FIG. 16A, with the screen removed.

FIG. 17 shows a perspective view of a reservoir embodiment, attached to and supplied water by a sump wall overflow.

FIG. 18A shows a perspective view of a reservoir embodiment, self supported on a transparent growth container.

FIG. 18B shows a perspective view of the reservoir embodiment of FIG. 18A, lifted out of the transparent growth container.

FIG. 19 shows a perspective sectioned view of a submersible illumination emitter embodiment of the current invention.

FIG. 20 shows a perspective sectioned view of a previous art submersible illumination emitter.

FIG. 21 shows a perspective sectioned view of components of a submersible illumination emitter embodiment before molding.

FIG. 22 shows another perspective sectioned view of the components of FIG. 21, of an embodiment of the current invention.

FIG. 23 shows a perspective sectioned view of the resulting molded embodiment using components of FIGS. 21 and 22.

FIG. 24 shows a perspective sectioned view of the resulting demolded embodiment of FIGS. 21, 22 and 23.

FIG. 25 shows a perspective sectioned view of components of another submersible illumination emitter embodiment before molding.

FIG. 26 shows a perspective sectioned view of components of another submersible illumination emitter embodiment before molding.

FIG. 27 shows a perspective sectioned view of components of yet another submersible illumination emitter embodiment before molding.

FIG. 28 shows a perspective view of 3D printed macroalgal attachment material that is an embodiment of the current invention.

FIG. 29 shows a perspective drawing representing 3D printed methods for making macroalgal attachment materials of the current invention.

#### DETAILED DESCRIPTION

Several embodiments of the invention with reference to the appended drawings are now explained. Whenever the shapes, relative positions and other aspects of the parts described in the embodiments are not clearly defined, the scope of the invention is not limited only to the parts shown, which are meant merely for the purpose of illustration. Also, while numerous details are set forth, it is understood that some embodiments of the invention may be practiced without these details. In other instances, well-known circuits, structures, and techniques have not been shown in detail so as not to obscure the understanding of this description.

In the process of filtering water using algal filtration, the challenge has been how to grow algae easily so the algae can be removed or harvested, thus removing the nutrients from the water. If the algae are not removed they will simply die and put nutrients back into the water. For biomass growth and production, the challenge has been how to grow enough biomass, in a small space, quickly and cheaply. Algae, either for filtering or for production, fall into two main algae categories: uni-cellular and multi-cellular. Uni-cellular algae are microscopic organisms which drift freely in the water

6

(e.g. plankton) and give the water a usually green tint. Therefore uni-cellular algae are usually called “micro” algae or “phyto” plankton. Multi-cellular algae are seaweeds that usually attach themselves to a surface. Since multi-cellular seaweeds are much larger than microalgae, they are usually called “macro” algae. It is these multi-cellular attached macroalgae seaweeds that are the focus of several of the embodiments described herein, and particularly in the descriptions below, care should be taken to observe whether the term used is microalgae or macroalgae because microalgae is a liquid that can be pumped or poured, whereas macroalgae is a solid that must be pulled or scraped.

#### PREVIOUS ART

The applicant’s invention of the first waterfall version of an “algae scrubber” was in 2008 and was dedicated to the public domain, and has had tens of thousands of aquarists build and operate it successfully. The basic operation of a waterfall version “algae scrubber” is: Water flows down a rough surface such as a screen, and is illuminated on one or both sides of the screen. The combination of illumination, rough screen surfaces, turbulent air/water interfaces, and nutrients in the water cause algae to attach and grow on the screen thus removing nutrients from the water because the algae utilize these nutrients for growth. The algae is subsequently removed (harvested) so that the nutrients are removed also, thus completing the filtering function of the algae scrubber, or the cultivation function of the cultivator. Filtering and cultivation are the same chemical process, just described differently depending on the application; thus herein when an algae scrubber is described it also refers equally to a cultivator.

The applicant’s subsequent invention of the gas bubble Upflow Algae Scrubber® (also identified as UAS®) version of an algae scrubber in 2011 (U.S. Pat. No. 9,115,008) with its companion gas bubble distribution system in 2013 (U.S. Pat. No. 9,334,184) was the opposite of a waterfall and allowed an algae scrubber or cultivator apparatus to be operated partially or completely submerged, thereby occupying little or no space above the water. This upflow design also eliminated any possibility of the algae drying out if water flow were stopped, because it was always submerged. It also could not overflow onto the floor if a drain clogged because it was already submerged and thus had no water draining. Many aquarium owners however still desire the original waterfall version if for no other reason than these designs have been around for a longer time, and these people have gone to great lengths to make space for the waterfalls to operate above the ambient water surface level in their sumps, and subsequently have tolerated overflows, drying out, water spray, large and heavy frames, and the hassles of disassembly and removal that are needed for cleaning/harvesting of these previous art waterfall designs.

FIG. 10 shows the basic functionality of the original previous art waterfall style “algae scrubber” as invented by the applicant and dedicated to the public domain in the year 2008. Water delivery structure 230, which was usually a PVC (polyvinylchloride) plumbing pipe 230, was fed by a water supply source (not shown). Pipe 230 had a slot (not shown) cut through its bottom side, and an algal attachment screen 240 with algal attachment surface 241 that was inserted up into this slot and held in place with screen attachment means 235 which was usually plastic tie-wraps 235. It is important to understand that screen 240 was not placed behind pipe 230 as it may appear in the drawing; screen 240 was instead inserted up into pipe 230 through a

slot in the pipe. When water flowed into pipe **230** and then out of the slot, the water flowed down and stayed mostly in contact with attachment surface **241**. This flowing turbulent water was illuminated on one or both sides by an illumination device **250** which was usually an LED or fluorescent bulb. Because the water came from an aquarium which had nutrients such as ammonia, ammonium, nitrite, nitrate, phosphate and CO<sub>2</sub>, photosynthetic algal growth **520** occurred which used these nutrients to grow and attach to surface **241**. Cleaning/harvesting of the growth **520** (and thus nutrients) occurred by the user turning off the water supply source to pipe **230** and then removing the screen attachment means **235** and algal attachment screen **240** from water delivery structure **230**; the growth **520** was then scraped off of surface **241** and discarded and screen **240** was replaced back into the slot of pipe **230** for more growth to occur.

FIG. 1 shows another previous art original waterfall algae scrubber **100** from the year 2008. These waterfall designs were almost always positioned above a sump **110** where they sat on a shelf **115**, and the sump itself was usually below a “display” aquarium **120**. Water flowed from aquarium **120** down to sump **110** and was pumped back up to aquarium **120** using a pump and piping not shown. Many different things could be put into sump **110**, however because algae scrubber **100** was a waterfall it needed to go above the ambient water surface level **130** of sump **110** so water could drain back down into sump **110**. This placement not only blocked access to things that were kept in the water **130** of sump **110** but also blocked some access to the space above sump **110**.

FIG. 2 shows an exploded view of the previous art algae scrubber **100** of FIG. 1. Water in sump **110** was pumped by water pump **210** through water source tubing **220**, through coupler **225**, until water reached water delivery structure **230** which here was a water pipe **230**. Water then flowed out of an orifice slot (not shown) cut into the bottom of water pipe **230** and flowed down algal attachment screen **240** (held in place with screen attachment means **235**) where the water was then illuminated by illumination devices **250**. Illumination from illumination devices **250** traveled through illumination ports **260** which were built into the sides of water delivery support walls **270**. Water delivery support walls **270** included cutouts **280** to hold water delivery pipe **230** in place during the starting and stopping of pump **210** because of the change of water pressure which tended to move water delivery pipe **230** laterally. Lid **290** held water delivery pipe **230** into cutouts **280** and also helped to contain illumination from escaping upwards. Water and sometimes algal growth flowed down drain pipe **295** to the ambient water surface level **130** below, and if pipe **295** became clogged with algal growth then secondary drain pipe **297** took over so that floods did not occur, because if water delivery support walls **270** filled up with water then an overflow would flow onto shelf **115** and then onto the ground of the room where the sump was located.

For cleaning/harvesting, lid **290** was removed and water delivery pipe **230** with water supply source tubing **220** was raised above water delivery support walls **270** in a similar fashion to this exploded drawing. Screen attachment means **235** were usually “zip ties” or “tie wraps” and were cut off, and the algal attachment screen **240** was then removed from the slot in water delivery pipe **230** and taken to a sink or elsewhere to be scraped clean of algal growth; the cleaned screen **240** was then replaced back into position in water delivery pipe **230**, new screen attachment means **235** were added, pipe **230** was lowered back into locking position in cutouts **280** of water delivery support walls **270**, and lid **290**

was put back into position. Sometimes drain **295** or the interior area between water delivery support walls **270** would require a more thorough cleaning, and thus the entire algae scrubber would need to be lifted from shelf **115** and taken to a sink for disassembly, a process that could take several hours if there was encrusted lime/carbonate buildup that needed to be cleaned. The cleaning/harvesting process was typically repeated every 7 to 14 days.

Illumination devices **250** were protected from water by a transparent shield such as glass or acrylic over illumination ports **260**, and were also somewhat protected by shelf **115** from water splashing up from the ambient water surface level **130**. Illumination devices **250** might also have had a protective covering **255** directly over the illumination emitters. Illumination devices **250** had to be moved outwards as shown in this exploded view, or the algal attachment screen **240** had to be lifted upwards, in order to clean/harvest the growth on screen **240**, or even to view the growth through illumination ports **260**.

Because water delivery pipe **230** had to be held in position during operation, and because it supported all the weight of a fully grown and wet screen **240** in addition to water in pipe **230** itself, pipe **230** needed support from water delivery support walls **270**. This was especially true because pipe **230** was connected to water source tubing **220** which sometimes had large volumes of water flowing, and when water pump **210** was turned on or off this hose **220** would jump or move around much like a garden hose when the water starts or stops. Thus support walls **270** of the structure were usually constructed of thick acrylic, usually black to contain illumination. Lid **290** sometimes was made very thick and heavy also, or had a locking feature, which prevented water delivery structure **230** from moving out of position should it be bumped accidentally. And since illumination devices **250** needed to illuminate through supporting walls **270**, transparent acrylic windows **260** needed to be added, thus increasing cost and complexity because two types of acrylic needed to be fabricated together (black to stop illumination, and transparent to enable illumination) usually in a waterproof manner. This substantially solid, heavy, and fragile acrylic enclosure comprised the majority of the high cost of the waterfall designs, and was very difficult and expensive to ship.

Moving illumination devices **250** away from water delivery support walls **270** required that the illumination devices **250** themselves be self contained devices, sealed and protected from moisture and breakage, with a frame or attachment mechanism that had to be released before movement could occur. Similarly, moving algal attachment screen **240** upwards usually required that the entire water delivery source tubing **220** be lifted also, in which case water continued flowing out of the orifice slot of water delivery pipe **230** in no particular direction; or that coupler **225** be decoupled so that water delivery source tubing **220** could be disconnected from the water delivery pipe **230**, but this required water pump **210** to be turned off so spraying would not occur out of the open end of water source tubing **220**. Thus in this original previous art waterfall algae scrubber from the year 2008, any method of gaining access to the algal attachment screen **240** required substantial disassembly of different components, especially if the entire algae scrubber were to be lifted up and removed, and these components added to the complexity, space, and cost.

Besides the space occupied by the waterfall algae scrubber above ambient water surface level **130**, other common complaints concerned the noise that the drain **295** made. Because illumination devices **250** were usually metallic,

they had to be positioned far enough up above ambient water surface level **130** so no splashing water reached them. This elevated distance required drainage pipe **295** to be connected to the drain orifice (not shown) of the algae scrubber, and thus drainage pipe **295** was the source for relatively loud gurgling and surging as water drained rapidly out of the water delivery support walls **270**. Further, when rapidly draining water impacted the ambient water surface level **130** below, many gas bubbles were produced in sump **110** which then circulated back to the display aquarium. Lastly, macroalgal growth tended to extend downward from attachment screen **240**, subsequently piling up and attaching to the bottom of water delivery structure support walls **270**. Thus when pipe **230** and screen **240** were lifted up for cleaning, macroalgae was torn apart from the bottom of support walls **270** and this caused clumps of algae to fall into sump **110** where the algae then circulated back to the display aquarium. Large portions of algae also sometimes fell onto the ground. As of October 2016, this method of constructing “enclosed” style waterfall algae scrubbers that the applicant dedicated to the public domain in 2008 is still the standard, and thus no low cost enclosed versions have been available.

#### DEFINITIONS

**Algae Scrubber:** An apparatus that uses illumination, rough surfaces, and a turbulent air/water interface to purposely grow attached macroalgae on the rough surfaces; the growth of this macroalgae removes or “scrubs” nutrients out of the water. Although algae had been utilized previously to consume nutrients from water, it was Walter Adey’s U.S. Pat. No. 4,333,263 in the year 1980 that described how to utilize a turbulent air/water interface to greatly increase the rate of the algal growth; the turbulence removed the invisible boundary layer around the algae, and this allowed nutrients to enter the algae faster. The main differences in the types of algae scrubbers since then have centered on how to provide the turbulent air/water interface, and how to provide convenient placement and cleaning.

**Waterfall Algae Scrubber:** A version of an algae scrubber that generates the turbulent air/water interface by utilizing a cascade of water down a substantially vertical algae-attachment surface. This version of the algae scrubber was invented by the applicant in 2008 and was dedicated to the public domain. It is the opposite of upflow style gas bubble algae scrubbers as described in applicant’s U.S. Pat. No. 9,115,008. For the purposes of the present application, waterfalls can also include any algae scrubber design that utilizes gravity to pull water down across the algal attachment surface, and thus requires placement above the ambient water surface level; such designs might include sloped-river designs, and dumping-bucket designs, although the applicant did not invent these.

**Macroalgal Attachment Material:** A material, including any mounting component, which is disposed in or on an algae scrubber and which has at least one rough macroalgal attachment surface to increase the ability of macroalgae to attach and grow on. This material, and any mounting component, might be removed from the algae scrubber in order to scrape, clean, or otherwise harvest macroalgal growth from the macroalgal attachment surface, or the material might be scraped, cleaned, or otherwise harvested in-place while still disposed in or on the algae scrubber apparatus.

**Enclosure Structure:** The totality of components that partially or wholly surrounds a waterfall algal attachment surface and also possibly a waterfall water delivery structure, such that illumination, water spray, and algal growth

are substantially contained within the enclosure. In the current application an enclosure structure comprises at least a dome, the dome actually being any suitable shape. An enclosure structure is wholly or partially removable or repositionable so as to enable substantial access to an algal attachment surface for observation and cleaning/harvesting.

**Dome:** A removable or repositionable portion of an enclosure structure which substantially encloses an algal attachment surface and also possibly a water delivery structure. A dome has an external surface and a concave internal surface, and it may be substantially opaque, and may have illumination devices on its external or internal surface. A dome may substantially rest upon an algal settlement structure, in which case when the dome is removed or repositioned the algal settlement structure remains stationary.

**Illumination Substantially Reduced:** A low enough level of illumination lux traveling from inside an enclosure structure to outside the enclosure structure such that a user can comfortably perform duties in an around the sump area without the illumination causing visual difficulties for the user. Common lux reduction values are 50% to 100%.

**Access Substantially Increased:** A high enough level of access to an algal attachment surface to enable a user to observe growth on the algal attachment surface and also to physically clean/harvest the majority of growth from the algal attachment surface without needing to remove or reposition the attachment material relative to the apparatus, aquarium or sump where the apparatus is located. In other words, substantial access allows in-place harvesting of growth without having to move many things.

**Headspace:** The open space above the water surface level in a reservoir compartment. The top of the reservoir compartment may have a lid, however the lid is generally not air tight and thus allows the level of the water (and air) to vary up and down in the compartment. Headspace can be visualized by filling a bowl halfway with water; the unfilled upper portion of the bowl is the headspace.

**Reservoir Structure:** A structure defining a reservoir compartment, a water inlet to the compartment, and a water outlet structure further defining a water outlet from the compartment. The reservoir compartment itself may function as the water outlet structure. A reservoir structure enables the flow of water through the reservoir compartment from the inlet to the outlet, and the outlet may be coupled to a water delivery structure which delivers water to an algal attachment surface, or the reservoir structure may itself be a water delivery structure to an algal attachment surface; the reservoir structure may also be all or part of the physical support structure of the waterfall algae scrubber apparatus.

Depending on the dimensions and shape of a reservoir structure, it may reduce water turbulence inside the reservoir compartment (a taller compartments may have less turbulence at its floor) and may also help to distribute water inside it across a larger algal attachment surface more evenly. When the reservoir structure provides physical support to a waterfall algae scrubber apparatus, the reservoir structure may also function as a pole mount, which might be self supporting from a floor of a sump. Reservoir structures, and their internal reservoir compartments, differ from water pipes primarily due to the generally open roofs (“reservoir top openings”) of reservoir compartments, and if a lid is utilized on a reservoir compartment or reservoir structure it is generally not air tight. Thus the air pressure in a reservoir compartment is generally at the atmospheric pressure of the location where the apparatus is located, and a headspace of air may develop inside the reservoir compartment. In contrast, the water pressure inside a water pipe is generally

elevated above the atmospheric pressure of the location where the apparatus is located, and there generally is no headspace inside the pipe. Thus a water pipe enables water to “squirt” out of the water pipe, possibly upwards into the air above the level of the pipe.

**Reservoir Top Opening:** A generally large opening located at an upper section of a reservoir structure, the opening being in fluid communication with the reservoir compartment of the reservoir structure. A reservoir top opening is generally not sealed and thus is open to the atmospheric pressure of the location where the reservoir structure is operating. Although there may be a lid on the opening, it is generally not air tight and thus may allow the reservoir compartment water surface level to fluctuate up and down. Water may overflow out of the opening, in which case the opening is also a water outlet. Water may also or alternately be poured into the opening, in which case the opening is also a water inlet. A reservoir top opening may be sized and shaped to complement the shape of the reservoir compartment so as to allow the user to access to the compartment, and/or to make manufacturing easier.

**Ambient Water Surface Level:** The water surface level in a sump or other location where an algae scrubber apparatus is disposed. Water from the waterfall algae scrubber drains down onto the ambient water surface level, and must then be pumped back up to the waterfall water delivery structure in order to recirculate. This recirculation path may include passing through other areas of an aquarium structure such as the “display” which houses the livestock.

**Reservoir Compartment Water Surface Level:** The internal water surface level in a reservoir compartment inside a reservoir structure. This internal water surface level will always be above the ambient water surface level, unless the waterfall itself is submerged.

**Pole Mount Reservoir:** A reservoir structure which physically supports a waterfall algae scrubber. Because the physical support, water supply source, and also possibly the drain are contained within a single support column of the pole mount reservoir, cost and space are considerably reduced. A pole mount reservoir may operate with or without headspace inside the reservoir compartment. In the present application, “pole mount” means the same as pole mount reservoir, e.g., it is a mount with upflowing water inside it.

**Water Delivery Structure:** A structure that is in fluid communication with, and supplies water to, a macroalgal attachment surface. A water delivery structure may receive water from a water supply source tubing or a reservoir compartment in a reservoir structure, or another source. Some examples of water delivery structures are a water pipe with a slot, a water pipe with holes, an open trough that overflows, and an open trough with a slot at its bottom. A water delivery structure may also be a reservoir structure by itself, whereby the reservoir structure delivers water directly to a macroalgal attachment surface. Or a water delivery structure may be a combination of pipes, troughs and reservoir structures.

**Perpendicular Access:** Ability of the user to make optical and physical contact with a macroalgal attachment surface by looking at or touching the attachment surface from a direction that is perpendicular to the attachment surface, without requiring removal or repositioning of the macroalgal attachment structure or a macroalgal settlement structure (illumination devices, however, may still need to be removed or repositioned). This is in contrast to a conventional box placed around a macroalgal attachment material which requires the removal of the material from the box, or the box from the material, in order to clean/harvest the

growth, and in some cases even to view the growth. If the macroalgal attachment material is not planar, then a direction of perpendicular access would be that which offered the greatest access to the material. Perpendicular access is very important for harvesting, and is defined further in FIGS. 13A, 13B and 13C.

**Macroalgal settlement structure:** A structure that catches macroalgae that settles or falls down from a macroalgal attachment surface, yet enables perpendicular “open” access to the macroalgal attachment surface for cleaning/harvesting because the macroalgal settlement structure is below the macroalgal attachment surface including any water delivery structure. The macroalgal settlement structure does not interfere with observation or cleaning/harvesting of the macroalgal attachment surface (the settlement structure is physically “open” on the areas that are in front of the growth surfaces); thus the macroalgal settlement structure does not need to be removed or repositioned in order for cleaning/harvesting to occur. The macroalgal settlement structure has an “open” settlement surface, which is open laterally like a food plate, and not closed like a box with walls. A macroalgal settlement structure may also act substantially as a support for positioning a dome, and could be substantially stationary when the dome is removed or repositioned.

**1-Sided or 2-Sided Macroalgal Attachment Material:** If a macroalgal attachment material does not allow substantial illumination and water from one side of the material to reach the other side of the material, then it is 1-sided because each surface cannot benefit from the illumination and/or water flow from the other side. However if the material is thin and porous enough, and possibly also translucent enough, then some illumination and water flow from one surface will travel through the material so as to keep the algal “roots” alive longer on the other side, enabling the roots to stay attached to the material longer before dying and detaching (algae can only stay attached when alive). An example of 2-sided material is common plastic canvas “cross stitch” grid used for knitting; illumination and water travel easily through the material. String is another example, because it is too thin to block much water or illumination. An example of 1-sided material is a sheet of metal; even though it is thin and can be made rough on both sides so that algae can attach, no water or illumination can travel from one side to the other side and thus the metal is essentially two 1-sided surfaces which do not benefit each other.

**Submerged Gas Compartment:** An internal compartment of a submerged enclosure structure which operates similar to a diving bell. This compartment contains some or all of the water delivery structures and algal attachment structures.

**Submerged Water Surface Level:** The internal water surface level within a submerged gas compartment. This internal water surface level will always be below the ambient water surface level during operation.

**Air tight:** Substantially sealed so that gas cannot escape. A dome can be air tight so that it can operate as a diving bell, however this does not imply that bottom open sections of the structure must be sealed. An air tight dome can hold gas under water without the gas escaping upwards, even though its lower sections are not sealed or closed, just like a cup turned upside down can hold air under water.

**Single Unified Component:** A component made to perform the functions of multiple separate components but made as a single indivisible component which cannot easily be separated without destroying it. Most often a single unified component is made with molded plastic.

#### Illumination Domes

FIG. 3 shows an embodiment of the current invention which utilizes the previous art water delivery pipe 230,

screen 240, shelf 115 and pump 210 of FIG. 2, but with an enclosure structure defining an illumination dome 310 (shown divided into two halves) and a macroalgal settlement structure 330 (which in this embodiment resembles a flat tray), the dome 310 utilizing submersible illumination devices 320 described below. When illumination dome 310 is removed or repositioned in this embodiment, access to half of the algal attachment screen 240 occurs in a single step, without having to remove or reposition screen 240, water delivery structure 230, tray 330, or a separate illumination device. Dome 310 may rest in a first position on a surface such as a macroalgal settlement structure 330 as it does in this drawing, or dome 310 may hang in a first position suspended from water delivery pipe 230 or another structure adjacent to the algae scrubber. By contrast, attaching downward pointing illumination devices to the bottom of the removable previous art lid 290 in FIG. 2 would have caused illumination to be blocked by water delivery structure 230.

In this drawing, 50% of illumination dome 310 is raised upwards to a second position for observation or cleaning/harvesting of algal attachment screen 240, however any percentage or part of dome 310 may be designed to be removed or repositioned to a second position in order to view or access the space inside it, such as 5% or 10% for viewing, or 20%, 30% or 40% for partial cleaning/harvesting, or 60%, 70%, 80%, 90% or 99% for a full cleaning/harvesting in one step while still allowing a small portion of dome 310 to remain attached in a first position to water delivery structure 230 or tray 330. Cutout 315 in the elevated portion of dome 310 (in second position) allows that portion of dome 310 to slide down into first position over water delivery pipe 230, however dome 310 could also have a moveable door that encloses cutout 315 once in the lowered first position, or dome 310 could be enlarged so as to completely enclose cap 335 and coupler 225 when in the lowered first position, leaving only the water supply source tubing 220 to protrude out of dome 310.

Illumination dome 310 is defined by a generally concave inner surface 311, a generally convex outer surface 312, and a bottom edge 316 which forms a shape that complements the size and shape of tray 330. If no tray 330 is utilized, then dome 310 may be structured with a bottom edge 316 which forms a very narrow bottom shape such that minimal illumination escapes out of the lower portion of dome 310 while still enabling dome 310 to be positionable and removable from water delivery structure 230. Such a narrow shape of bottom edge 316 might be 5 mm larger than the width of water delivery pipe 230, which would still allow dome 310 to be lifted up.

Measuring the escapement of illumination from an enclosure structure can be done by placing the algae scrubber in an opaque box of similar size to a typical sump (possibly 1 meter wide, 1 meter tall, and 0.5 meters deep) which is white inside to reflect illumination, and then placing a standard illumination/lux meter inside the box. With the algae scrubber illumination devices 320 not illuminated, the lux meter should read zero. When illumination devices 320 are illuminated and the algae scrubber enclosure structure (310, 330) is enclosed in the first position (operating position), the lux meter measurement is taken. Then dome 310 or a portion of dome 310 is removed for cleaning/harvesting and the lux measurement is taken again. For example, if the measurement of a lux meter were 5 lux with dome 310 in first position, and 500 lux with dome 310 in second position, then illumination reduction would be 99%. Acceptable levels of illumination reduction could be 50%, 60%, 70%, 80%, 90%,

95%, 99%, and 100%. Another way to measure illumination escapement is with absolute lux at the location where the users eyes would be during observation of the apparatus. When dome 310 in the first position (operating), and with all other illumination sources removed or turned off, a lux meter held at the position of the user's eyes and pointed at the apparatus should preferably measure less than 100 lux, and more preferably less than 50 lux, and even more preferably less than 20 lux, and even more preferably less than 10 lux, and even more preferably less than 5 lux, and most preferably 0 lux.

The enclosure structure (310, 330) can be any size, shape or material that provides substantial illumination reduction when dome 310 is in a first position (enclosed) similar to the lowered half of dome 310, yet allows substantial access to algal attachment screen 240 when dome 310 is in a second position (opened) similar to the raised half of dome 310. For example, dome 310 and tray 330 might be made of injection molded thermoplastic such as ABS or polycarbonate, or a thermoset resin such as polyurethane. The material could be any color, or coated with any color, however usually only opaque dark colors will keep a substantial amount of illumination from traveling through the material. Lighter colors, however, especially white, reflect more light inside the enclosure structure (310, 330) and thereby increase the effective amount of illumination reaching algal attachment screen 240. Thus a two-color or two-material enclosure structure (310, 330) might be utilized, being white inside and black outside. Metal or metal foil will block illumination as well, but generally should not be used due to their chemical effect on some livestock.

In embodiments such as FIG. 3 where dome 310 supports illumination devices 320, the dome 310 should be made of material to both support the weight of, and be protected from the heat of, illumination devices 320. However because the submersible illumination devices 320 (described below) are small and lightweight with no metal to corrode, illumination devices 320 can be attached to an interior surface 311 of dome 310 with no special structure or heat reduction required of dome 310. This combination of a simple and lightweight dome 310 and illumination device 320 allows for easy access to algal attachment screen 240 by lifting up dome 310, much like lifting the lid of a cake display tray.

Other embodiments might utilize illumination devices (not shown) which are external to dome 310 and which project illumination through an illumination port similar to port 260 in FIG. 2, in order to illuminate algal attachment screen 240. These illumination devices might be attached to an external surface 312 of dome 310, thus being removed with dome 310; or they might be attached to an upper surface 331 of tray 330, in which case they would remain stationary with tray 330 as dome 310 was removed. Lastly, illumination devices might be attached to sump or aquarium objects near the algae scrubber, where the illumination devices are entirely separate from the algae scrubber but still project illumination through an illumination port in dome 310.

The shape of external surface 312 and internal surface 311 of dome 310 can be any shape which enables the structure 310 to support itself and any illumination devices 320 that may be attached, and which block a substantial amount of illumination from reaching the user. The bottom edge 316 of dome 310 could be shaped to set in a first position inside of a sidewall 333 that goes around the edge of tray 330; this would further help to contain illumination as well as water spray and algal growth. The shape of macroalgal settlement structure 330 could be just a flat shelf which supports dome

15

310 in a first position, possibly with pegs or notches or a sliding rail to hold dome 310. Or tray 330 could have a sidewall 333 around it as shown, in order to further hold and position dome 310 in the first position. If a sliding rail (not shown) is used to hold dome 310 in a first position on tray 330, then dome 310 could slide on the rail, either laterally or upwards, to an open second position. Tray 330 might include orifices for drain pipes such as drain pipe 295, and backup drain pipe 297, or tray 330 might not have any orifices at all and may just allow overflowing over the edges of tray 330 or sidewall 333. Lastly, the enclosure structure might not include a tray 330, in which case the bottom of dome 310 would remain open and water flowing off of algal attachment screen 240 would not be contained at all. 100% containment of illumination, as measured with a light/lux meter, is possible however if enclosure structure (310, 330) completely seals or surrounds water delivery structure 230 in addition to other structures. Any illumination that might escape down drain 295 or alternate drain 297 can be reduced or eliminated by appropriate shaping or shading of those orifices, and making those orifices black colored.

Sidewall 333 might be a short lip around the edge of tray 330; possibly only 2 to 10 mm above the top surface 331 of tray 330. Or sidewall 333 might be taller, perhaps 10 to 50 mm above top surface 331, in order to contain growth that accumulates at, or falls off of, the bottom of algal attachment screen 240. The height of sidewall 333 might be below the bottom of illumination devices 320, in which case the illumination from illumination devices 320 would travel over sidewall 333; this would allow sidewall 333 to be made of an opaque white material to reflect more illumination inside dome 310. Or the height of sidewall 333 might be above illumination devices 320, in which case sidewall 333 might be made of a transparent or translucent material so that illumination from illumination devices 320 travels through sidewall 333. Alternately, sidewall 333 might instead include an illumination port similar to label 260 of FIG. 2.

#### Example Claims—Illumination Domes

1. An apparatus for enclosing a waterfall algae scrubber or seaweed cultivator, comprising:
  - an enclosure structure movable from a first position to a second position, the first position enclosing an algal attachment surface such that illumination from inside the structure is substantially reduced before traveling outside the structure, and the second position such that access to the algal attachment surface is substantially increased.
2. The enclosure structure of claim 1, wherein the enclosure structure substantially encloses a water delivery structure.
3. The enclosure structure of claim 1, wherein an illumination device is attached to the enclosure structure.
4. The enclosure structure of claim 3, wherein the illumination device is attached to an exterior surface of the enclosure structure such that illumination from the illumination device is directed to travel through an illumination port.
5. The enclosure structure of claim 3, wherein the illumination device is attached to an interior surface of the enclosure structure.
6. The enclosure structure of claim 1, wherein perpendicular access to the algal attachment surface is at least 50% more when the enclosure structure is in the second position than when in the first position.
7. The enclosure structure of claim 1, wherein escaped illumination measured in lux when the enclosure structure

16

is in the first position is at least 50% less than when the enclosure structure is in the second position.

8. The enclosure structure of claim 1, wherein the enclosure structure defines a tray and a dome, the tray having an upper surface and being substantially stationary, the dome having an external surface and a concave internal surface and being substantially supported by the tray and moveable from a first position to a second position.
9. The enclosure structure of claim 8, wherein the tray includes sidewalls.
10. The enclosure structure of claim 9, wherein the height of the sidewalls is lower than an illumination device.
11. The enclosure structure of claim 9, wherein the sidewalls are translucent or transparent and the height of the sidewalls is above an illumination device.
12. The enclosure structure of claim 1, wherein the enclosure structure substantially encloses all water delivery devices and algal attachment surfaces.
13. The enclosure structure of claim 12, wherein the enclosure structure is substantially air tight.
14. The enclosure structure of claim 13, wherein the enclosure structure defines a tray and a dome, the tray having an upper surface and being substantially stationary, the dome having an external surface and a concave internal surface and being substantially supported by the tray and moveable from a first position to a second position.
15. The enclosure structure of claim 14, wherein the tray includes sidewalls.
16. The enclosure structure of claim 15, wherein the height of the sidewalls is lower than an illumination device.
17. The enclosure structure of claim 15, wherein the sidewalls are translucent or transparent and the height of the sidewalls is above an illumination device.
18. The enclosure structure of claim 13, wherein the enclosure structure includes an air-bleed valve.
19. The enclosure structure of claim 13, wherein the enclosure structure is injected with gas.
20. The enclosure structure of claim 19, wherein the gas is injected by an air pump.
21. The enclosure structure of claim 19, wherein the gas is injected by a Venturi valve attached to a water delivery source.
22. The enclosure structure of claim 19, wherein the enclosure structure is weighted so as to remain submerged.
23. The enclosure structure of claim 1, wherein the enclosure structure defines a dome, the dome having an external surface and a concave internal surface and being substantially supported in the first position by a water delivery device.
24. The enclosure structure of claim 23, wherein illumination from the apparatus as measured in lux at a location of a user's eye is to be less than 100 lux when the dome is in the first position.
25. The enclosure structure of claim 23, wherein the dome includes an illumination device attached to an internal surface of the dome.
26. The enclosure structure of claim 23, wherein the illumination device is attached to an exterior surface of the enclosure structure such that illumination from the illumination device is directed to travel through an illumination port.
27. An enclosure structure substantially as hereinbefore described with reference to FIG. 3.

#### Pole Mount Reservoirs

FIG. 4 shows an embodiment of the current invention which utilizes a pole-mount reservoir 410 as well as a



non-divided illumination dome **310** shown in a first position which encloses substantially all of the water delivery structure and algal attachment surface inside it. A pole mount reservoir is called such because in addition to its mounting function, it is generally a larger diameter than a simple water pipe and thus holds more water similar to a reservoir.

Because a shelf is no longer needed as in FIG. 3 label **115**, there is no possibility of overflowing onto the floor, and thus no secondary backup drain is needed; drain **295** provides all needed drainage and in effect the entire enclosure structure is its own backup drain because any clogging of drain **295** simply causes water to flow down the sides of the algae scrubber to water surface **130** of sump **110** where it would have gone anyway. And because pump **210** pumps water through water source supply tubing **220** up through the inside of pole-mount reservoir **410**, no pipes or tubing need to go through dome **310**; thus dome **310** can be constructed of just one simple lightweight box or dome shape without any cutouts or ports. Very lightweight and low cost materials such as corrugated plastic or thermoformed styrene may be used. If illumination devices (not shown) are mounted on the tray instead of dome **310**, then dome **310** carries no weight and can be made of plastic as thin as 0.5 mm, and if the shape of dome **310** is made to be rectangular then it could fold flat for shipping. Therefore by utilizing pole-mount reservoir **410** with illumination dome **310**, manufacturing costs are reduced, spills on the floor of the room are eliminated, space above the algae scrubber is increased, and access to the water in the sump is also increased because of the removal of the shelf. The sump itself may also be less costly because of this. Lastly, pole mount **410** and drain **295** might be angled instead of vertical as shown; an angle of 10, 20, 30, 40, 50, or 60 degrees from vertical reduces or eliminates the falling sound of water within drain **295**. If drain **295** were coupled to pole mount **410**, then drain **295** could aid pole mount **410** in providing support, and one or both could be angled.

FIG. 5 shows the embodiment of FIG. 4 with the illumination dome **310** raised upwards to a second position and with the assumption that illumination devices (not shown) are mounted to the interior of dome **310**. Instead of utilizing alternate drain **297** in FIG. 2 as a drain, it is instead utilized in exactly the opposite way: it is reversed in flow so that water flows up into the algae scrubber instead of down out of it, and its pipe is extended downward into sump **110** so that it can physically support the entire waterfall algae scrubber, thus becoming a pole mount reservoir **410** with coupler **420** and base **510**. Water supply tubing is not normally thought of as a support structure such as this. A lightweight illumination dome **310** can then replace the heavy and bulky illumination devices **250** of FIG. 2 because heavy supporting walls **270** of FIG. 2 are no longer needed. In FIG. 5 these changes completely eliminate water delivery support walls **270**, the heavy and bulky illumination devices **250**, and the portion of water source supply tubing **220** which rises above ambient water surface level **130**. Thus by moving the water supply source from above the algae scrubber to below it, and also by utilizing this same water source as a physical support mount, the high cost construction and space utilization problems of FIG. 2 are solved, including shelf **115** which is no longer needed. And although described as a "pole", the shape of pole mount reservoir **410** can be any height, width, cross sectional area, or cross sectional shape such that it functions as described herein.

Illumination dome **310** is shown raised upwards into a second position for observation/cleaning/harvesting of algal attachment screen **240** and/or water delivery structure **430**.

Water is pumped by pump **210** through the submerged portion of water supply source tubing **220** into pole mount reservoir **410** and then through coupler **420** into water delivery structure **430**, which in this embodiment is comprised of a vertical and horizontal pipe connected together with an elbow fitting. Water then flows down attachment surface **241** of attachment material **240** onto algal settlement tray **330**, and then continues down drain **295** back down to ambient water surface level **130** of sump **110**. Lightweight illumination dome **310** has internal illumination to facilitate algal growth **520**, and this combined with the small space requirement of water delivery structure **430** allows for a very compact and low cost construction because algal settlement tray **330** must only support algal growth **520**, lightweight dome **310**, and drain **295**. And if dome **310** is held in position by water delivery structure **430**, then tray **330** only need support algal growth **520** and drain **295**.

When lowered to a first position where it is touching algal settlement tray **330**, especially when surrounded by sidewall **333**, illumination dome **310** completely encloses water delivery structure **430** thus requiring no components to intersect dome **310**. Thus raising dome **310** to second position as shown is relatively easy because no water delivery pipes or long water supply source tubings are attached or pass through dome **310** as they do in FIG. 2. Lastly, water flowing up pole mount reservoir **410** can continue when dome **310** is raised to the second position during observation of the growth, because the flow of water through water delivery structure **430**, down algal attachment surface **241**, onto tray **330**, and down drain **295**, is not interrupted as it would be in FIG. 2. Further simplicity may be had by routing drain **295** downwards through pole mount **410** such that water exits below ambient water surface level **130**, as will be shown in a subsequent drawing; this allows the algae scrubber to be essentially a single column. It is also contemplated that the diameter of pole mount reservoir **410** could be enlarged to match the width and shape of tray **330**, thus making a true single column apparatus.

Coupler **420** is attached or molded on to algal settlement tray **330** such that pole mount reservoir **410** and/or water delivery structure **430** decouple from tray **330** for cleaning/harvesting. Pole mount **410** or its base **510** which sits on the floor of sump **110** may be weighted so that pole mount **410** stays stationary in sump **110** while tray **330** and water delivery structure **430** are removed; this preserves the positional relationship between water delivery structure **430** and tray **330** which helps prevent algal growth from being pulled apart. Coupler **420** could alternately be attached or molded on to both tray **330** and pole mount **410**, whereby only water delivery structure **430** would decouple, leaving tray **330** and pole mount **410** remaining in the sump. Lastly, coupler **420** could be releasably attached to water delivery structure **430**, tray **330**, and pole mount **410** so that they could all be removed separately.

Macroalgal settlement surface **331** defines a plane that is represented by rectangle **530** which is shown at the same elevation as surface **331** by dotted line **540**. One of the defining factors of a pole-mount embodiment of the current invention is that the water can be supplied to the apparatus from below the apparatus through pole mount reservoir **410** instead of from above the apparatus as in previous art algae scrubbers. So by requiring that the path of water through pole mount **410** (and water delivery structure **430**) intersect plane **530** of settlement surface **331**, it can be seen how water must then come from below surface **331** instead of from above it. Furthering this concept is requiring that pole mount **410**, or water delivery structure **430**, actually contact



macroalgal settlement structure **330** such as it does in FIG. **5**. Such contact might be a simple weighted tray **330** that sits on a lip of pole mount **410**, or a releasable mechanism that allows easy detachment of tray **330** from pole mount **410**, or tray **330** might be permanently coupled to pole mount **410**, possibly by being made of the same molded material as pole mount **410**. And although shown that pole mount **410** transitions to water delivery structure **430** at the point of intersection with tray **330**, the transition could instead be above or below the point of intersection. Lastly, water delivery structure **430**, settlement structure **330**, and pole mount **410** could be a single unified component.

FIG. **6** shows a pole mounted algae scrubber embodiment similar to FIG. **5** except the algae scrubber is positioned just above the ambient water surface level **130** of sump **110**. This position contributes even more open space above sump **110**, and eliminates the need for drain pipe **295** of FIG. **5** entirely because the drain orifice (not visible) is essentially now already at the height of the ambient water surface level **130**. This eliminates all gurgling and surging sounds produced by some drain pipes, and further reduces cost by requiring less length for the long pole mount reservoir **410** of FIG. **5**. And the physical strength needed by tray **330** can be even further reduced because if dome **310** hangs on water delivery structure **430** of FIG. **5** instead of sitting on tray **330**, then tray **330** need only support algal growth **520** of FIG. **5** and nothing else. Pump **210** might also be made smaller because the required height that water must be pumped up to is less; water supply source tubing **220** would carry the same volume of water however.

The water level **130** in many sumps varies greatly, and this is another reason why previous art waterfall algae scrubbers were positioned far above (10-30 cm) the ambient water surface level **130**. However the current embodiment of FIG. **6** has no problem with a rising water level **130** at all, because at worst, the water inside dome **310** overflows tray **330** and spill back down to water level **130** where it would have gone anyway. The algae scrubber will continue to operate in elevated water levels **130**, although the effective waterfall distance inside dome **310** will be less as the water level **130** rises. This too can be accounted for as shown in the next figure.

FIG. **7** shows a pole mounted embodiment similar to FIG. **6** with the same pump **210** and water tubing **220**, except that dome **310** is now an air tight illumination dome **310** for submerged operation. Air tight dome **310** can be an illumination dome **310** as in the previous figures or it can be a dome without attached illumination, instead enclosing a stationary illumination device that perhaps is attached to tray **330**. Dome **310** is shown mostly submerged below ambient water surface level **130**, however dome **310** could instead be operated totally submerged, or slightly submerged, depending on the ambient water surface level **130** in sump **110**. Any part of the apparatus, including base **510** if dome **310** were latched on to tray **330**, might be weighted so as to keep the apparatus submerged. Submerged operation such as this can require the least amount of space of all the waterfall embodiments, and can be made to be dry-out (desiccation) proof as shown in the next figure. It is also contemplated that pump **210** could be self contained within base **510** or pole mount **410**, thus eliminating tubing **220** and adding weight to keep the structure submerged.

A submerged waterfall embodiment such as this has interesting applications, such as the possibility of placing the algae scrubber in the actual aquarium instead of the sump. Users typically prefer to not have waterfall algae scrubbers above their aquariums because of the large space occupied

by the scrubber; this space is usually needed to access the inside of the aquarium from the top. Also, the draining of water into the aquarium from above it tends to splash, and in saltwater aquariums it causes a buildup of salt on nearby surfaces and wires. Lastly, an escapement of illumination from previous art scrubbers is very visible above an aquarium, especially at night. Previous art scrubbers almost never block all illumination from escaping because of the bulky illumination devices that must be easily removed for observation and cleaning; they cannot be completely sealed shut.

The present invention embodiment however allows a waterfall algae scrubber to be placed submerged in the main aquarium, possibly hidden behind (or decorated as) rocks or plants, with no splashing or gas bubbling (very little gas escapes dome **310**), and with practically no escapement of illumination. For aquariums without sumps, the submerged waterfall embodiment of FIG. **7** may be the only option if the user desires a waterfall algae scrubber instead of an upflow scrubber (as described in applicant's U.S. Pat. No. 9,115,008). Small aquariums also, such as the popular desktop "all in one" styles that have pseudo sumps on their back walls (instead of beneath), might also have smaller sized waterfall algae scrubber embodiments installed which can fit into one of the submerged compartments in the back. Operation of the submerged embodiment of FIG. **7** is shown in FIG. **8**.

FIG. **8** shows an underwater cutaway view of the submerged embodiment of FIG. **7**. Dome **310** is shown almost completely submerged beneath ambient water surface level **130**, with only the topmost portion of dome **310** above water surface **130**, as well as an air-bleed valve **830**. Because dome **310** is an air tight enclosure per the definition herein, pushing dome **310** below the water surface **130** causes the submerged water surface level **810** inside dome **310** to also push downwards, just as if you took an empty cup and pushed it under water while it was upside down (open side facing down). It's also the same concept as a diving bell, which has an open port on the bottom to allow divers to jump "down" into the water even though the whole structure is already submerged. Therefore it can be seen here where the ambient water surface level **130** exists on the outside of dome **310** but this water level does not continue to exist on the inside of dome **310**. The inside is dry. And this allows the waterfall algae scrubber to operate under water.

The air pressure inside dome **310** keeps the submerged water surface level **810** approximately at the bottom edge **316** of dome **310**, which is also approximately at the bottom level **810** of drain orifice **820** of algal settlement structure tray **330**. Tray **330** is not needed for submerged operation however; if tray **330** were removed then submerged water surface level **810** would remain approximately the same. Weights (not shown), or a weighted material to make dome **310** heavier, holds dome **310** down so that it rests on tray **330** and does not float upwards. Alternately as explained in FIG. **7**, dome **310** might be latched onto tray **330**. As in FIG. **5**, water is pumped up through pole mount **410**, through coupler **420**, into water delivery structure **430** where it then flows down algal attachment screen **240**. Illumination is provided on the rear side of screen **240** with illumination device **320**; a second device **320** on the front side of screen **240** is not visible in this cutaway view.

The pumping of water into submerged compartment **840** would normally cause air to be pushed downward out of drain orifice **820**, which does occur to a small extent when the flow out of water delivery structure **430** first begins, however once flowing, this new quantity of water then exits submerged compartment **840** through orifice **820**, thus

equalizing the pressure inside submerged compartment **840** (water input equals water output) so that submerged water level **810** remains approximately constant. Some leakage via gas bubbles does occur out of drain orifice **820** when water is flowing rapidly down algal attachment screen **240** because of turbulence and entrained gas bubbles created when water impacts tray **330** (or impacts submerged water level **810**). If this gas leakage were not replaced, internal water level **810** could slowly rise inside dome **310**. Replacing this escaped gas can be done by injecting gas into dome **310** directly, or into the flow of water going through pole mount **410** by using gas tube **850**, either of which could be done with an air pump. Injecting gas into pole mount **410** via gas tube **850** also has the option of using a Venturi valve as shown by applicant's U.S. Pat. No. 9,115,008 in FIG. 3, label 305. If operated as a Venturi tube, gas injection tube **850** could be extended upwards so that it pulls air from above ambient water surface level **130**.

Besides the relatively small space occupied by this algae scrubber under water, submerged operation offers an advantage to users who have electric utility power outages on a regular basis. With above-water waterfall algae scrubbers, an electric power outage stops the water flow to the algae scrubber, causing any growth on the algal attachment screen **240** to eventually dry out and die. However because dome **310** is submerged in this embodiment, compartment **840** can be allowed to slowly fill with water so as to keep the algal growth wet; wet growth can stay alive for many days without any water flow or illumination, thus giving the user time to restore electrical power. This filling of dome **310** with water can be accomplished by air bleed valve **830**. When an electric power outage occurs, gas injection into dome **310** will stop and air bleed valve **830** will allow gas inside submerged compartment **840** to slowly escape, such that submerged water level **810** will slowly rise until it is level with ambient water surface level **130**. This will then keep algal attachment screen **240** submerged until electric power is restored. Air bleed valve **830** could be adjusted by the user so that very little gas normally escapes, thus reducing the required volume of injected gas during normal operation, yet still allowing submerged compartment **840** to fill with water when needed to keep algal growth alive.

Another useful application of a submerged embodiment is automatic feeding for livestock. As just explained, turning off electric power can enable compartment **840** to fill up with water. At these times, and if there is no tray **330** (or if drain orifice **820** is large enough), livestock can enter compartment **840** and eat algal growth that has grown on material **240**. Then when electric power is restored, gas will once again start to fill compartment **840** and the livestock will be pushed out downwards. Automatic feeding can also be accomplished with upflow scrubbers (U.S. Pat. No. 9,115,008), however they are never lifted above the ambient water surface level and thus cannot use gas as a way to prevent livestock from eating the algal growth continuously.

FIG. 9 shows a pole mount reservoir embodiment **900** which is the embodiment of FIG. 5 but with the upper portion **930** removed for cleaning, harvesting, or maintenance. In this embodiment **900**, upper portion **930** includes water delivery structure **430**, coupler **420**, macroalgal attachment material **240**, macroalgal settlement tray **330**, and drain pipe **295**. Coupler **420** is shown attached to algal settlement tray **330** which is attached to drain pipe **295**, thus enabling drain pipe **295** to be removed for cleaning because it often clogs when algal growth is thick; coupler **420** is also shown attached to water delivery structure **430** which is attached to algal attachment screen **240**, thus enabling any

macroalgal growth, including algae settled upon algal settlement tray **330**, to be easily removed together for harvesting. This is useful because as shown in FIG. 5 and FIG. 10, the macroalgal growth **520** in those figures tends to extend downward from attachment surface **241**, subsequently piling up on settlement tray **330**, sometimes several centimeters thick. Thus by keeping screen **240** and tray **330** together as they are removed for cleaning, algal growth **520** in FIG. 5 and FIG. 10 will not be pulled apart; pulling macroalgae apart can cause pieces of algae to fall into the sump where the algae will circulate back to the aquarium; large portions of algae might also fall on to the floor. Coupler **420** is shown detached from water outlet **920** of pole mount reservoir **410** and base **510**; unlike previous art FIG. 2 where continuing to operate water supply source pump **210** would cause water to be sprayed randomly, in FIG. 9 it can be seen that water supply source pump **210** could continue to operate, having water only to smoothly overflow back downwards because of the slow velocity of water inside large diameter pipe **410**. When upper portion **930** is lowered back into operating position, coupler **420** releasably positioned on pole mount reservoir **410**, possibly with a friction fit or held in place by the weight of the upper portion **930**. Locking, alignment, or other latching mechanisms could also be utilized to keep algal settlement tray **330** horizontally level or in a particular orientation; this would prevent rotation around pole mount reservoir **410**.

At first it did not seem like good practice to detach upper portion **930** of a structure that had upflowing water in it, only to leave a lower portion still in position in a sump, because if this were done with water flowing then the water might shoot upwards out of outlet **920** causing short circuits of nearby electrical wires in the sump area. Similarly, when upper portion **930** is lowered into operating position, the water velocity from the lower section might push upper section **930** back upwards. Even though locks could be used to hold the upper portion **930** into operating position, this requires extra hardware and time to lock it, and also requires the user to remember to lock it, which may not always happen. However by utilizing pole mount reservoir **410** for the mount, instead of a narrow water pipe, it turns out that the large diameter of pole mount reservoir **410** enables the upwards velocity of water to be much slower than a narrow pipe for a given amount of water volume. Thus not only does the larger diameter of pole mount reservoir **410** provide for a stable physical mounting base, and the larger amount of water in mount **410** adds weight and even more stability, but the reduced water velocity inside it allows the water to continue to flow in a slow controlled manner when upper portion **930** is removed; the water just smoothly overflows back down the external walls of pole mount reservoir **410**. The upper portion **930** need not be locked down into position, and water flow need not be turned off. Water pump **210**, tubing **220**, water inlet **910**, and base **510** remain in sump **110** or can also be removed for cleaning or maintenance. When the user needs to remove the entire algae scrubber **900** from the sump, the water pump **210** is turned off and water inside mount **410** drains out, making the structure lightweight for removal.

Typical water flow values for an algal attachment screen **240** of width 25 cm are 1500 lph (liters per hour); for such a water flow the pole mount reservoir **410** has an inside diameter of 5-8 cm, thus providing strong physical support if made of standard PVC pipe without causing water to shoot up into the air when upper portion **930** is lifted. A larger algal attachment screen **240** of width 50 cm has 3000 lph of water flow, and pole mount reservoir **410** has an inside diameter of

10-12 cm. As long as water does not rise up more than about 3 cm above water outlet **920** when upper portion **930** is lifted, then the inside diameter of pole mount reservoir **410** should be sufficient as long as it provides enough physical support for the weight of upper portion **930**.

#### Example Claims—Pole Mount Reservoirs

1. An apparatus for supporting macroalgal attachment material and supplying water to a macroalgal attachment surface, comprising:
  - a macroalgal attachment material defining a macroalgal attachment surface;
  - a macroalgal settlement structure defining a macroalgal settlement surface;
  - a water delivery structure, the water delivery structure to intersect a plane (**530,1470**) of the macroalgal settlement surface;
  - a positioning mechanism, the positioning mechanism to position the macroalgal attachment material such that the macroalgal attachment surface receives water from the water delivery structure;
  - an attachment mechanism, the attachment mechanism to couple the macroalgal settlement structure to the water delivery structure and to align the macroalgal settlement surface such that macroalgae is enabled to travel from the macroalgal attachment surface to the macroalgal settlement surface.
2. The apparatus of claim 1, wherein the water delivery structure and the macroalgal settlement structure remain coupled when the macroalgal settlement structure is removed for cleaning/harvesting.
3. The apparatus of claim 2, wherein the water delivery structure and the macroalgal settlement structure remain in position relative to each other when the macroalgal settlement structure is removed for cleaning/harvesting.
4. The apparatus of claim 1, wherein the macroalgal attachment material is supported by the water delivery structure.
5. The apparatus of claim 1, wherein the macroalgal attachment material is supported by the macroalgal settlement structure.
6. The apparatus of claim 1, wherein the water delivery structure is a water pipe.
7. The apparatus of claim 1, wherein the water delivery structure is a reservoir.
8. The apparatus of claim 1, further comprising:
  - a pole mount;
  - a pole mount coupler, the pole mount coupler to couple the macroalgal settlement structure to the pole mount such that water traveling up the pole mount continues to travel into the water delivery structure.
9. The apparatus of claim 8, wherein the pole mount supports the apparatus from ground level (**1170**).
10. The apparatus of claim 9, further comprising a drain pipe, the drain pipe coupled to the pole mount.
11. The apparatus of claim 9, wherein the drain pipe is disposed within the pole mount
12. The apparatus of claim 11, wherein the drain pipe is angled.
13. The apparatus of claim 1, further comprising:
  - a pole mount;
  - a pole mount coupler, the pole mount coupler to couple the water delivery structure to the pole mount such that water traveling up the pole mount continues to travel into the water delivery structure.
14. The apparatus of claim 13, wherein the pole mount supports the apparatus from ground level (**1170**).

15. The apparatus of claim 13, further comprising a drain pipe, the drain pipe coupled to the pole mount.
16. The apparatus of claim 15, wherein the drain pipe is disposed within the pole mount
17. The apparatus of claim 17, wherein the drain pipe is angled.
18. The apparatus of claim 1, wherein the water delivery structure and the macroalgal settlement structure are a single unified component.
19. The apparatus of claim 8, wherein the pole mount and the macroalgal settlement structure are a single unified component.
20. The apparatus of claim 8, wherein the pole mount, macroalgal settlement structure, and water delivery structure are a single unified component.
21. An apparatus for supporting macroalgal attachment material and supplying water to a macroalgal attachment surface substantially as hereinbefore described with reference to FIGS. **4-9**.

#### Reservoir Overflows

FIG. **11** shows an embodiment **1100** of the present invention which is essentially what remains after upper portion **930** in FIG. **9** is removed. As a matter of fact, it was while drafting FIG. **9** and describing the overflowing action of water down pole mount **410** that it was realized that pole mount **410** would grow algae on itself if illuminated, and therefore could operate independently as a very simple waterfall algae scrubber embodiment itself if algal attachment surfaces were placed on its external wall and if illumination were pointed at these surfaces. Algal growth on plumbing tubing is normally not desired on aquarium equipment, but because of the small footprint required on the sump floor, and the small number of components required, this embodiment is ideal for many situations. “External surface” is defined herein to be the outside wall (of a pipe or structure) that contacts the ambient air or water surrounding the pipe or structure, and is the surface the user sees when looking at apparatus **1100** while in operation. In contrast, “internal surfaces” of a pipe or structure would not be in contact with the surrounding air or water, and would not be visible to the user in normal operation unless the user purposely looked inside of the pipe or structure.

Pole mount reservoir **410** is supported by base **510** which sets at ground level **1170** of a sump (not shown). Water pump **210** pushes water through water supply source tubing **220** into pole mount reservoir water inlet **910**, where the water then flows up an internal surface **1180** of a reservoir compartment (not shown) inside pole mount reservoir **410**. Because embodiment **1100** is essentially made of a single length of plumbing pipe, internal surface **1180** of the internal reservoir compartment is simply be the inside surface (inside diameter) of pole mount reservoir pipe **410**.

Because water continues to flow upward and out of pole mount reservoir **410**, if the water does not have enough upwards velocity to “shoot” up into the air above outlet **920** then the water will overflow the rim of outlet **920** and turn downwards in the direction of arrow **1110** where the water then flows down external surface **1160** of pole mount reservoir **410**. One way of keeping the upwards velocity of water low so that it does not shoot up into the air is to define that the area of water outlet **920** which is represented by circle **1191** be larger than the area of water inlet **910**; the area of water inlet **910** is approximately the cross sectional area of water pump tubing **220**. This will slow down the velocity of water from pump **210** as the water enters pole **410**,

although of course the volume of water in liters per minute will be the same. For example, under typical aquarium sump operating conditions of a 10, 15 or 20 cm diameter pole **410**, if the ratio of water outlet area **920** to water inlet area **910** is at least 5, then the upwards velocity of water inside pole **410** should not be enough to shoot into the air more than 3 cm above pole **410**. Larger ratios such as 10, 15, 20, 30, 40 or 50 would allow even more water to be pumped by pump **210** into larger diameter reservoirs **410** without the water shooting into the air more than 3 cm

After overflowing the rim of water outlet **920**, the water then comes into contact with algal attachment surface **1130** of macroalgal attachment material **1140** before finally returning back to ambient water surface level **130** (represented as line **130**) of the sump (not shown). If the plane that is represented by rectangle **1190** of the rim of outlet **920** is substantially horizontally level, similar to cup of water on a table, then the downward water flow will contact attachment surface **1130** in a substantially equal amount around the circumference of pole mount reservoir **410**. The combination of water flow, rough attachment surface **1130**, and illumination from an illumination source such as source **1145** causes macroalgal growth **520** to attach to and grow on attachment surface **1130**. And although FIG. 9 shows pole mount reservoir **410** supporting and mounting upper portion **930**, in FIG. 11 pole mount reservoir **410** is essentially supporting and mounting itself and macroalgal attachment material **1140**, and thus continues to be a mount as well as a reservoir.

Two features of embodiment **1100** are of note: The first is that the water overflows substantially all the way around pole mount reservoir **410** outlet **920** instead of just part of outlet **920**. Whether the shape of pole mount reservoir **410** (or outlet **920**) is round as shown or another shape such as square or rectangular, this feature of water overflowing substantially equally around the entire circumference of outlet **920** maximizes the utility of pole mount reservoir **410** compared to water simply overflowing over a portion of the circumference, or over a wall such as a sump wall, which is normally thought of when a waterfall is described. All parts of the rim and pole are utilized for algal attachment and for receiving illumination, not just some parts. And because pole mount reservoir **410** physically supports itself above ambient water surface level **130**, this usage of the entire circumference of pole mount reservoir **410** allows the maximum area of algal attachment surface **1130** for a given size of pole mount reservoir **410**, thus minimizing manufacturing costs. Alternately to complete circumference water flow, a cap **1196** (shown separate from apparatus **1100**) with water outlets **1197** could be placed on top of outlet **920** so as to provide a cover. It is contemplated that water outlets could additionally be located below outlet **920** in wall **1150**, although they would need to be reduced in size because of the increase in water pressure below outlet **920**.

The second feature of note is that only a single thin wall **1150** is needed for the structure of pole mount reservoir **410**. Water flowing up the internal reservoir compartment of pole mount reservoir **410** will be in contact with internal water retaining compartment surface **1180** of wall **1150**, and the resulting overflowing water coming downwards will be in contact with external surface **1160** of pole mount reservoir **410** where attachment material **1140** is disposed. This usage of water coming into contact with both sides (internal and external) of a single wall **1150** all the way around the circumference of pole mount reservoir **410** again makes maximum usage of the structure of pole mount reservoir **410**, as compared to for example a horizontal river algae

scrubber design which only makes use of an upper surface of its entire structure, or an overflowing wall of a sump which only makes use of one of its several walls. Typical thicknesses of wall **1150** might be the same as the pipe used to construct it: 2-5 mm for typical aquarium sump applications. If large tubing such as 30 cm diameter is utilized, then wall **1150** thickness might be as high as 10 mm. If decorations such as gravel or rock are placed on external surface **1160** then the operating thickness will be wall **1150** thickness plus decoration thickness. This decoration may also act as the attachment material **1140**, in which case the external surface of the decoration could be attachment surface **1130**. Further, the thickness of a decoration might vary based on location on external surface **1160**. For example, the entire algae scrubber **1100** might be decorated as a volcano, with 1 cm decoration thickness at the level of water outlet **920**, and 20 cm decoration thickness at the ambient water surface level **130**. Thus if wall **1150** thickness of pipe **410** were 1 cm, the effective wall thickness would be at total of 2 cm at water outlet **920**, and a total of 21 cm at water surface level **130**.

Embodiment **1100** makes further use of the concept of utilizing the majority of its structure, by physically supporting itself on base **510** which rests at ground level **1170** which may be the floor of a sump. Although FIG. 9 shows pole mount reservoir **410** also physically supporting upper section **930** on base **510**, upper section **930** is a separate, additional set of components. Contrastingly, FIG. 11 shows pole mount reservoir **410** to be practically the entire algae scrubber itself. In fact if water pump **210** is not taken into consideration or were included inside of pole mount **410**, and if pole mount reservoir **410** had a large enough diameter to prevent falling over, and if macroalgal attachment surface **1130** were obtained by simply roughing up the exterior surface **1160** of pole mount **410**, then the total number of components required to construct this embodiment would be just one (the pole).

Embodiment **1100** also has advantages of non-clogging, and self-correcting flow. Regular water hoses with slots or small holes (often used in gardening to soak the soil) can lose flow because the small orifices are easily clogged by particles in aquarium water, or by hard lime/carbonate buildup similar to that in showers and sinks. The large outlet **920** on pole mount reservoir **410** however would rarely clog if the diameter of outlet **920** were just one centimeter or larger; and since it is contemplated that the diameter of outlet **920** would be in excess of 3-10 cm, it could be stated that a clog would simply never occur. And if plane **1190** of outlet **920** were substantially horizontally level, then any non-balanced flow would self correct because when a section of the rim of outlet **920** begins to have larger/higher algal growth than other sections do, it will start to block and slow down water flow at that section and will thus increase flow at other sections on the rim. Thus the areas of higher algal growth on the rim of outlet **920** will then receive less nutrients from the reduced water flow and will begin to grow less compared to the shorter growth areas which now receive more overflowing water flow and more nutrients. The sections with shorter algal growth will then soon catch up with the taller sections, and the amount of water overflowing the rim around the circumference of outlet **920** will again be equalized. The area **1191** of outlet **920** on pole mount reservoir **410** might be equal to or greater than the area of the reservoir compartment's water surface (not shown) on the inside of pole mount reservoir **410**, or the area **1191** of outlet **920** might be less, such as 90%, 80%, 70%, 60%, or 50% of the area of the reservoir compartment's water surface. This

reduced outlet **920** area reduces the volume of water required to completely overflow all portions of the rim of outlet **920**.

Lastly there is the possibility of embodiment **1100** being self-stabilized at ground level **1170** solely from the weight of the water inside it with no base **510** or additional weights required. There are factors that the user has control over which also determine stability, such as the height of the ambient water surface level **130** (a lower water level **130** increases the relative weight and thus stability of pole mount reservoir **410**) and the placement of illumination devices on one, two or multiple sides of pole mount reservoir **410** (algal growth on one side would be least stable whereas growth on all sides would be most stable), however the stability is generally sufficient when the height-to-diameter ratio is less than 2 when the height of ambient water surface level **130** is below half the height of pole mount reservoir **410**. For example if the height of pole mount reservoir **410** is 30 cm (from bottom **1195** to outlet **920**) and the inside diameter is 15 cm, and if the ambient water surface level **130** is 15 cm (half the height of pole mount reservoir **410**), then the weight of the water inside pole mount reservoir **410** when operating should by itself provide enough stability to keep pole mount reservoir **410** in a vertical operating position without additional weights or braces, and without base **510** being needed. This is especially true if pump **210** is disposed inside and at the bottom of pole mount reservoir **410**. This simplicity enables pole mount reservoir **410** to be constructed with just a single section of circular or square tubing, sealed at the bottom **1195** at ground level **1170**. If water pump **210** is disposed in the bottom of pole mount **410** then the entire structure **1100** can be lifted out and taken to a sink for cleaning without having to disconnect anything.

Also with regards to weight is the advantage that embodiment **1100** has when water pump **210** is turned off; water drains back out of pole **410** via pump **210** or via a separate small drain hole (not shown), and this removes a large amount of weight from embodiment **1100**. This is important for sump areas with fragile equipment, so pole **410** can be removed for cleaning without knocking other things over. If pole **410** is made of lightweight and thin wall pvc pipe such as type "SDR-35" sewer drain pipe, then a 6" (15 cm) diameter of height 24" (60 cm) would only weigh about 2 kg when empty, compared to 12 kg when full. This full-to-empty ratio is 6 and is typical of embodiment **1100** because almost all of the structure is used for water containment internally and growth surface externally. Other full-to-empty weight ratios might be 5, 4, 3, or 2 for smaller diameter reservoirs **410** because more weight of material is used for a given size of reservoir, or 8, 10, 12, 15, 20 or 30 for larger diameter reservoirs **410** because less weight of material is used for a given size of reservoir.

Maximizing effectiveness with minimal material can also be achieved by defining that embodiment **1100** have a high amount of internal water reservoir volume compared to external algal attachment area, especially when the embodiment is not a simple cylindrical pipe. For example a 100 cm tall volcano decoration as described above with an external algal attachment surface **1130** area of 10,000 square cm with a common 1" (2.5 cm) diameter water pipe **410** (water volume=490 cubic cm) inside it would have a volume/area ratio of 0.049 which is very low. However if a 6" (15 cm) diameter pipe **410** were used instead (water volume=17,663 cubic cm) then the ratio would become 1.77 which is much higher. And the larger pipe would have a more realistic larger water outlet **920** at the top of the volcano decoration which would further provide benefits no clogging or water

shooting into the air. Other types of decorations or structures might have less external area, thus the volume/area ratio would be higher. A straight cylindrical pipe with no decorations has the highest ratio (6" pipe ratio=3.75 and 1" pipe ratio=0.62) and larger diameter pipes have higher ratios than smaller diameter pipes, but the ratio should generally be more than 1.0 including decorations.

If the user has a very crowded sump with no room for base **510** or even a large diameter reservoir **410**, it may be desired to have a narrow but tall embodiment **1100**. It is contemplated that stability in this situation might be obtained by attaching a hanging means such as a wire or rope to an upper section of reservoir **410** near outlet **920**; the other end of the rope might be attached to the roof of the cabinet where the sump is located. Further, embodiment **1100** might actually be hung from this rope such that no part of reservoir **410** touches the sump; instead bottom **1195** could be at or just above or below ambient water surface level **130** and could actually be above other equipment in the sump so that no open space on the floor of the sump is needed at all for pole **410**. A very low cost version of this would be embodiment **1100** hanging from the hose that drains water from the aquarium down into the sump; a simple cylindrical bucket **410** with it's own hanging means would suffice as reservoir **410**, with algal attachment material **1140** attached to the exterior **1160** of the reservoir bucket **410**, and an aquarium drain hose inserted into the reservoir bucket **410** through opening **920**. The water capacity of the reservoir bucket **410** could be reduced to limit the hanging weight, and the attachment material **1140** could be lengthened beyond the bottom of reservoir bucket **410** so there would be more surface **1130** for algal growth to attach to and for illumination source **1145** to illuminate. It might appear to be a hanging mop.

Tall narrow embodiments are also useful if the user wishes to operate the apparatus outdoors using solar illumination. Pole **410** could be set up similar to fence posts, as tall as the user requires; this makes the most use of solar illumination because narrower that pole **410** is, the less shadow is casts on poles behind it, and the pole does not need to be a minimum diameter in order to capture the most illumination from an artificial illumination bulb source; solar light is free. Common fence materials be used such as hollow vinyl fence posts in 4", 5" or 6" (10, 12.5 or 15 cm) diameter sizes. After macroalgal attachment surfaces are added to the exterior of these posts they can be positioned relatively near each other so they can still grow substantial algae with solar illumination alone. Example dimensions of these posts **410** are 150 cm tall, and 15 cm outside diameter, giving a height-to-diameter ratio of 10. Other height-to-diameter ratios such as 15, 20, 25 or 30 make better use of the available ground area.

If the user wishes to reduce the overall area that algae grows on pole **410** because of smaller filtering needs or lack of water pump capacity, it is envisioned that partial or positional dam segments could be placed at outlet **920** such that water only flows down over a portion of the circumference of pole **410**. Cap **1196** would accomplish this, however the top of cap **1196** is closed. If the user prefers to keep water outlet **920** open so as to be able to reach down into pole **410**, then extending wall **1150** upwards in some sections of outlet **920** but not others would confine water flow to the desired sections. These extended upward sections of wall **1150** could be individual segments that could be added or removed from outlet **920**, thus allowing for adjustable flow levels and direction, or a cap **1196** could be used which itself has a removable top, thus keeping opening **1197**

in place to alter water flow but allowing the user to reach into pole **410** from the top. Changing algal attachment **1130** area and/or pole **410** height can also be accomplished with an adjustable-height pole **410**, possibly with a telescopic 2-section pole **410**; these sections could slide over one another and be locked down or glued by the user into position. A telescoping movement of pole **410** could also be achieved by a screw rotation of one section of pole **410** into the other section, and the needed screw threads might be molded into the material that pole **410** is made of.

Decorations can alter the stability. If the decorations are above ambient water surface level **130** then the extra weight of the decoration (and the water flow on it) farther away from the vertical axis of mount **410** will reduce stability, and thus lighter materials such as foam might be used and the thickness of the decoration minimized. If the decorations are below ambient water surface level **130** then the decorations should set on ground level **1170** and should be more dense than water so as to increase stability.

Macroalgal attachment material **1140** could be any material or surface in the art which enables substantial amounts of macroalgal (seaweed) growth **520** to attach and grow. For example, roughened plastic canvas in 1-3 mm thickness with 5-10 grids per inch as described in applicant's U.S. Pat. No. 9,115,008 could be permanently or removably secured to the exterior of pole **410**. If removable, the roughened plastic canvas could be removed for cleaning/harvesting without needing to remove pole **410** or turn off pump **210**. Material **1140** might be attached to pole mount reservoir **410** by friction fit, or supported by a lip at the bottom **1175** of material **1140** such that material **1140** could be lifted off of pole mount reservoir **410**. If pole **410** is square or rectangular, then material **1140** might just be a flat sheet the roughened plastic canvas which hangs on a flat side of mount **410**. Material **1140** might be rigid so as to maintain its shape (in FIG. 11, cylindrical) when removed, or it might be flexible or cloth-like, such that it can be flattened and scraped on a flat surface. Another material **1140** might be sand or small gravel of grain size 1-3 mm glued to pole **410** or to a sheet of plastic which is then wrapped around pole **410**. Yet another material **1140** might be a woven non-organic cloth such a polyamide (nylon) or fiberglass cloth in a very coarse 10-20 threads per inch density. Material **1140** might alternately be a 3D printed grid as described later in this application. Or material **1140** might simply be a roughened portion of the exterior surface **1160**; this simplifies construction and does not require disassembly however it requires either that the cleaning/harvesting be done while still in the sump, or that the entire apparatus **1100** be removed, possibly leaving only the pump **210** in the sump. To achieve a rough enough surface **1130** which allows macroalgal seaweed to attach, simple sanding of the exterior surface **1160** is not sufficient because heavy macroalgal seaweed growth **520** will fall off (thick growth can become 5 cm thick and weigh several kg per square meter). Instead, deep rough cuts **1130** will need to be made into the material of pole **410** such that shards or edges of the material stick out laterally 1-3 mm from exterior surface **1160**; this type of roughened surface **1130** sometimes resembles a cactus. If mount **410** is decorated such as the volcano described above, then material **1140** might be removable landscape textures that are or resemble sand or gravel.

If apparatus **1100** is to be operated in a sump with water level **130** then it is preferred that rough surface **1130** be above water level **130** (shown approximately at height **1175**) and not below it, so that debris circulating in the sump water will not be caught by surface **1130**. Rough surface **1130**

would thus be only on an upper portion of pole **410**. It is also envisioned that pole **410** might be utilized as the means of transferring water from the sump back up to the aquarium above it, and from the aquarium back down to the sump. In previous art, this transfer function was usually done by a separate pump (not shown), often called a "return pump" which pumped water from the sump up to the aquarium where the water then went through an overflow in the aquarium and then down through a drain hose back down to the sump. However embodiment **1100** can be utilized for this transfer function, thus eliminating the extra return-pump and extra overflow hose. To accomplish this, water pump **210** becomes the "return" pump, and pumps water into the bottom of pole **410** which then transfers this water up the inside of pole **410** to outlet **920** located in the aquarium above (water does not immediately overflow down pole **410**). Only after circulating within the aquarium above does the water then overflow from the aquarium down the outside of pole **410**, flowing down algal attachment surface **1130**. A water divider mechanism can be affixed to water outlet **920** to cause this desired flow pattern into and out of the aquarium; such a water divider mechanism is usually a wall with separate passages on each side of the wall. Pole **410** can also be made to be easily removed for cleaning/harvesting of growth from it, and pump **210** does not need to be turned off during cleaning because water will just recirculate in the sump. If pole **410** is utilized in this manner, rough attachment surface **1130** might only be on a lower portion of pole **410** such that the entire height of pole **410** need not be illuminated.

The diameter of pole mount reservoir **410**, other than being sized for a particular size of aquarium or sump, should be such that water overflowing in the direction of arrow **1110** be capable of completely overflowing the entire circumference of the rim of outlet **920** at normal operating water flow and subsequently also be capable of flowing down completely over all macroalgal attachment surface area **1130** completely around the circumference of attachment surface **1130** all the way around exterior surface **1160**. Generally this water flow (provided by water pump **210** or by another source) is at least 60 lph (liters per hour) per centimeter of overflow circumference. For example a pole mount reservoir **410** with outside diameter of 15 cm (radius of 7.5 cm) has an overflow circumference of  $2(\pi)(7.5)=47.1$  cm and thus should have a minimum total water flow of  $60(47.1)=2826$  lph. Similarly, a square shaped pole mount reservoir **410** with each side measuring 15 cm would have a total overflow circumference of  $4(15)=60$  cm, and thus would require at least  $60(60)=3600$  lph of total water flow. The diameter of pole **410** also has an effect on receiving illumination from illumination sources such as LED **1145** because a tall and narrow structure of embodiment **1100** would tend to allow some illumination to miss algal attachment surface **1130**. Thus by reducing the height-to-diameter ratio to below 2 as described above, the portion of embodiment **1100** above the ambient water surface level **130** will be wider and thus will receive more of the illumination. It is also contemplated that the height-to-diameter ratio might be less than 3, 4, 5 or 6. If decorations are added to the exterior of wall **1150** such as the example volcano described above (which is wider at the bottom than at the top) then the water flow may not completely cover all exterior surfaces **1130** at the bottom because of the much larger surface area there, even though the flow does covers all surfaces **1130** at the top.

An alternate embodiment of **1100** might change water inlet **910** to be at the top of pole mount **410** so that there is just one opening **920**, such that water enters pole mount

reservoir **410** from the top instead of from the bottom. In this case water is poured into outlet **920** from above, or a water supply source tubing might be inserted into outlet **920**. If a water supply source tubing is inserted into outlet **920** then the tubing might extend partially down into pole mount reservoir **410** or the tubing might extend substantially to the bottom of pole mount reservoir **410**. Extending further down into pole mount reservoir **410** gives less turbulence at outlet **920** because the water has a longer vertical distance to travel upwards before overflowing outlet **920** and has had more time to reduce any swirling or random motions, thus leveling the flow pattern overflowing outlet **920**. A more even flow pattern overflowing outlet **920** helps equalize algal growth on all sides of pole mount reservoir **410**. The water however still achieves a turbulent air/water interface motion when it falls down attachment surface **1130** thus maximizing photosynthetic growth and filtering.

Another alternate embodiment of **1100** has macroalgal attachment material **1140** located below pole mount reservoir **410** instead of on the side of pole mount reservoir **410**. This is possible if base **510** or a separate bracket (not shown) elevates pole mount reservoir **410** such that the bottom **1195** of pole mount reservoir **410** is above ambient water surface level **130**. This allows water to cascade off the bottom **1195** of pole mount reservoir **410**, and thus if macroalgal attachment material **1140** were disposed below pole mount reservoir **410** then the water would travel out of outlet **920**, down surface **1160**, then down to the attachment material **1140**. It is contemplated that base **510** could be discrete supporting legs, such as for a table, and this would enable attachment material **1140** to be wrapped around the legs like a fence, and an additional illumination source placed inside the legs which would then provide illumination on both sides of macroalgal attachment material **1140**. Attachment material **1140** could also be placed both below and on the sides of pole mount reservoir **410**. If material **1140** is string or ribbon as shown in FIGS. **9A-9E** of co-pending U.S. utility patent application Ser. No. 14/380,926 then water will flow on both the inside and outside of the material **1140**.

Yet another alternate embodiment of **1100** might have base **510** made of supporting legs with the attachment material positioned within the legs instead of around the legs, and pole mount reservoir **410** shaped in a pointed fashion, pointing down, such that water flowing down exterior surface **1160** converges at the bottom **1195** of pole mount reservoir **410** and thereby transfers to attachment material **1140**.

Illumination of pole mount reservoir **1100** could be solar if the apparatus were outside or near a window. For artificial illumination, any suitable illumination source could be utilized, especially long narrow sources such as fluorescent tubes or strings of LEDs (light emitting diodes) **1145** because they would complement the shape of pole mount reservoir **410**. If decorated, such as a volcano, then various illumination sources **1145** could be placed around the circumference of reservoir **410**.

FIG. **12** shows an embodiment **1200** of the current invention which utilizes multiple pole mount reservoirs **410** to support a bridging macroalgal attachment material **1210** which has a bridging macroalgal attachment surface **1215**. Embodiment **1200** also supplements water flow to middle sections **1240** of bridging macroalgal attachment material **1210** by utilizing water delivery structures **1220** which may be attached to pole mount **410** by any conventional means such as glue, welding, or friction fit. Because there is no waterfall delivery pipe with an orifice slot as was utilized in previous art FIG. **2** and FIG. **10**, there is nothing to clog with

growth. Instead water delivery structures **1220** of the current embodiment **1200** of FIG. **12** cannot clog because any growth on a water delivery structure **1220** simply causes water to flow up and over it where the water still falls into contact with bridging macroalgal attachment surface **1215**. The growth cannot stop the water.

Utilizing bridging macroalgal attachment material **1210** also allows for 2-sided macroalgal attachment instead of 1-sided. When algal growth **520** gets more than a few millimeters thick it begins to self-shade, such that the "root" layers of growth which attach to attachment surface **1215** receive less illumination and water flow than newer outer layers of growth do. This causes less growth for the important root attachment layers, and if illumination and water flow are reduced enough then the root layers will completely detach and flow away with the water. Thus by utilizing a thin bridging macroalgal attachment material **1210** and providing water flow and illumination devices **1145** on both sides of material **1210**, the roots of the macroalgae **520** will be kept alive and in full attachment for a longer period of time such that the algae can be cleaned/harvested properly instead of falling off prematurely onto the ambient water surface level **130** (represented by line **130**). This 2-sided concept is explained further in FIGS. **13A**, **13B** and **13C** below.

Water pump **210** pushes water through water supply source tubing **220** into a pole mount reservoir **410** through water inlet **910**, where the water is then divided into delivery pipes **1230** to the adjacent pole mount reservoirs **410**. However water supply source tubing **220** could instead have been itself divided using a standard pipe divider so that water flowed through multiple water supply source tubings **220** into each water inlet **910** of each pole mount reservoir **410**. Water then travels up the internal reservoir compartments (not shown) of each of the pole mount reservoirs **410** where the water then exits water outlets **920**, then the water both overflows the rims of outlets **920** and also comes into fluid communication with water delivery structures **1220** which direct the water to flow laterally away from the exterior surfaces **1160** of pole mount reservoirs **410** such that central portions **1240** of the bridging macroalgal attachment surfaces **1215** are contacted by the water. Thus the water delivery structures **1220** enable water to reach more bridging attachment surface **1215** than would otherwise occur. The flowing water, rough attachment surfaces, and illumination source **1145** cause algae to attach and grow, removing nutrients from the water.

Embodiment **1200** works well in solar illuminated outdoor pond applications because the large bridging material surface area captures sunlight well and can also be used as a fence to hold livestock. Pole mounts **410** cannot clog; a clog could be troublesome if the algae scrubber **1200** is not easily accessible such as in the middle of a pond. Algal attachment material (**1210**, **1140**) could be designed to slide upwards off of pole mount reservoirs **410** for cleaning/harvesting, or embodiment **1200** might not be cleaned/harvested at all. Non-cleaning of algae scrubbers changes their purpose from nutrient removal devices to nutrient conversion devices; nutrients in the water are simply converted from inorganic (ammonia, nitrite, nitrate, phosphate, CO<sub>2</sub>) into organic food for the livestock, thus keeping the water chemically "clean". Freshwater growth **520** tends to be long and stringy, which flows down to the pond water level **130** and gets eaten by the livestock, and growth **520** above the pond water line **130** tends to get consumed by snails that travel upwards. So a solar illuminated pond embodiment **1200** can be self-filtering and self-feeding once set up, only requiring a water pump **210** and tubing **220**.



FIG. 13A shows an example of a 2-sided macroalgal attachment material **240** (further described in applicant's U.S. Pat. No. 9,115,008 as used for an upflow version) supplied by water from a water source (not shown) from above material **240**. Arrow **1315** shows how illumination reaches the front side of macroalgal attachment material **240**, and arrow **1316** shows how illumination reaches the back side of macroalgal attachment material **240**. Water flow (not shown) flows down both sides of material **240**. Arrow **1316** is shown partially visible through material **240**, emphasizing the open or porous nature of material **240**. This open or porous structure allows illumination and water from the front of material **240** to also partially reach the back of material **240**, and vis versa. Macroalgal growth **520** is shown partially hanging off the bottom of material **240**, however it often starts its growth in thin layers which cover material **240** completely like a blanket; thus if arrow **1315** were illumination, it and water flow would have difficulty reaching the front surface of material **240** when growth **520** became thick across the whole width of material **240**. It is at this time that illumination represented by arrow **1316**, and also water flow from the back side of material **240**, penetrate material **240** to aid in keeping the algal roots alive on the front of material **240**. And the process is the same for illumination and water from the front of material **240** aiding the roots on the back of material **240**. It has been shown that this 2-sided construction can add up to a week of time before the "roots" begin to die and detach due to lack of illumination and water flow reaching the roots. This greatly increases (doubles) filtering capacity for the same size of apparatus.

FIG. 13B shows an example of a 1-sided macroalgal attachment material attached to a rectangular pole mount reservoir structure; the attachment material is fed by water overflowing out of outlet **920**. The walls of the structure are opaque, including left wall **1340** and front wall **1345**, thus illumination represented by arrow **1335** on the left wall and **1336** on the front wall does not travel through the attachment material. Nor does water. So when growth (not shown) gets thick on the attachment material, the roots which are nearest to the opaque walls of the structure will begin to die sooner than growth on FIG. 13A.

FIG. 13C shows another example of a 1-sided macroalgal attachment material attached to a cylindrical reservoir structure, the attachment material is fed by water overflowing out of outlet **920**. Cylinder wall **1365** is opaque as in FIG. 13B, so no illumination or water travels through the wall; illumination (represented by arrows **1370** and **1371**) and water flow are stopped.

FIGS. 13A, 13B and 13C also demonstrate "perpendicular access" for cleaning/harvesting. The same arrows **1315**, **1316**, **1335**, **1336**, **1370** and **1371** that represented illumination are also used here to represent the user reaching to the macroalgal attachment material to clean or harvest it. Perpendicular access is defined to mean the user having substantially open access to reach perpendicularly (or normal) to the growth surface, in the direction of the arrows. For example in FIG. 13A the user would have perpendicular access to the front or back of material **240** all the way across the material (even though the arrows are only on the left side of the material); in FIG. 13B the user would have perpendicular access to all four sides of the structure (even though only two arrows are shown); and in FIG. 13C the user would have perpendicular access all the way around the circumference of the cylinder (even though only two arrows are shown). In FIG. 13C especially, there would be substantially

no part of the structure of the waterfall apparatus on the sides of the cylinder that would prevent perpendicular access from any direction.

When applied to illumination domes as described in earlier figures, perpendicular access can be measured when the dome is in the first and second positions. Looking at FIG. 13A from the front, e.g. viewing from the direction of arrow **1315**, the macroalgal attachment material has an area that is its width multiplied by height. As shown in FIG. 13A which has no illumination dome, perpendicular access to material **240** would be 100% because all the area of the material is reachable. However if an illumination dome were placed on tray **330** in a first position, and the dome covered half of the width of material **240** such that only half the width were viewable and reachable, then the illumination dome would prevent perpendicular access to 50% of the attachment material. And of course if an illumination dome completely covered all of material **240** in the first position but allowed full access to all of material **240** when the dome was removed to a second position, then perpendicular access would be 0% in the first position and 100% in the second position. Perpendicular access is important for the cleaning and harvesting of algae scrubbers because it defines how many steps will be needed to obtain access to the growth; the less steps, the better.

Lastly, FIG. 13A also shows macroalgal settlement structure **330** supporting attachment material **240**. Material **240** is shown here rigid and attached to tray **330** using glue (not shown) or another standard attachment mechanism. Material **240** might instead be flexible and held up with vertical braces (not shown) attached to tray **330**. Material **240** might be several rigid upright structures, possibly with added weight that set on tray **330** and thus do not require a fastening mechanism. Being attached to or set on tray **330** instead of a water delivery structure ensures that macroalgae **520** will not be torn apart when tray **330** and material **240** are removed for cleaning/harvesting. Drain orifice **820** continues to allow drainage of water from tray **330**, when tray **330** collects algal growth.

#### Example Claims—Reservoir Overflows

1. An overflowing reservoir apparatus for supplying water to a macroalgal attachment surface, comprising:
  - a first reservoir structure (**410**), the first reservoir structure defining a first reservoir compartment, a first water inlet, and a first water outlet defining a first rim with a first circumference, the first reservoir compartment having a height and a diameter;
  - a first macroalgal attachment material defining a first macroalgal attachment surface;
  - a first attachment mechanism, the first attachment mechanism to position the first macroalgal attachment material such that water flowing out of the first water outlet flows down an external surface of the first reservoir structure and makes contact with the first macroalgal attachment surface.
2. The apparatus for supplying water of claim 1, wherein the first reservoir structure supports itself from ground level (**1170**).
3. The apparatus for supplying water of claim 1, wherein an external surface of the first reservoir structure and an internal surface of the first reservoir compartment are two sides of a same wall.
4. The apparatus for supplying water of claim 1, wherein the first rim of the first water outlet defines a plane, the plane being substantially horizontally level such that an amount



water flowing out of the first water outlet is substantially equal around the entire circumference of the first water outlet.

5. The apparatus for supplying water of claim 4, wherein the first macroalgal attachment material encircles the exterior surface of the first reservoir structure such that water flows down substantially equally around the circumference of the first macroalgal attachment surface.

6. The apparatus for supplying water of claim 1, wherein the first water outlet is open to the atmosphere.

7. The apparatus for supplying water of claim 6, wherein an area (1191) of the first water outlet is at least 50% of an area of the water surface inside the first reservoir compartment.

8. The apparatus for supplying water of claim 1, wherein a height to diameter ratio of the first reservoir compartment is less than 6.

The apparatus for supplying water of claim 1, wherein a ratio of first water outlet area (1191) to a reservoir compartment water surface level height is less than 3.

10. The apparatus for supplying water of claim 1, wherein the first water inlet is the first water outlet.

11. The apparatus for supplying water of claim 1, wherein a first water supply source tube is placed into the first water outlet.

12. The apparatus for supplying water of claim 11, wherein the first water supply source tube extends substantially to the bottom of the first reservoir compartment.

13. The apparatus for supplying water of claim 1, wherein the first macroalgal attachment material is positioned on a side external surface of the first reservoir structure.

14. The apparatus for supplying water of claim 1, wherein the first macroalgal attachment material is positioned below a bottom (1195) of the first reservoir structure.

15. The apparatus for supplying water of claim 2, wherein the weight of the first reservoir structure provides sufficient stability to keep the first reservoir structure in upright operating position when the first reservoir compartment is filled with water and the ambient water surface level is less than half the height of the reservoir structure.

16. The apparatus for supplying water of claim 1, further comprising:

a second reservoir structure, the second reservoir structure defining a second reservoir compartment, a second water inlet, and a second water outlet defining a second rim;

a second macroalgal attachment material defining a second macroalgal attachment surface;

a bridging macroalgal attachment material defining a bridging macroalgal attachment surface;

a second attachment mechanism, the second attachment mechanism to position the second macroalgal attachment material such that water flowing out of the second water outlet flows down an external surface of the second reservoir structure and makes contact with the second macroalgal attachment surface.

a third attachment mechanism, the third attachment mechanism to secure the bridging macroalgal attachment material to the first and second reservoir structures and to align the bridging macroalgal attachment surface such that a portion of the water which flows out of the first water outlet and a portion of the water which flows out of the second water outlet makes contact with the bridging macroalgal attachment surface.

17. The apparatus for supplying water of claim 16, further comprising:

a water delivery structure,

a water delivery structure attachment means, the water delivery structure attachment means to secure the water delivery structure to a reservoir structure and to position the water delivery structure such that it receives water flowing out of a water outlet and delivers a portion of the water to the bridging macroalgal attachment surface.

18. The apparatus for supplying water of claim 1, wherein a ratio of a first water outlet area to a first water inlet area is at least 5.

19. The apparatus for supplying water of claim 1, wherein the first macroalgal attachment surface is circular with a larger circumference at the bottom of the first reservoir structure than the top of the first reservoir structure.

20. The apparatus for supplying water of claim 3, wherein a thickness of the wall is less than 10 mm.

21. The apparatus for supplying water of claim 1, wherein a ratio of weight of the apparatus when full of water to a weight of the apparatus when empty of water is greater than 2.

22. The apparatus for supplying water of claim 1, wherein a ratio of first reservoir compartment volume to first macroalgal attachment surface area is at least 1.

23. The apparatus for supplying water of claim 1, wherein the first macroalgal attachment surface is a portion of an external surface of the first reservoir structure.

24. The apparatus for supplying water of claim 1, wherein the first macroalgal attachment material is removable from the first reservoir structure.

25. The apparatus for supplying water of claim 1, further comprising a water divider mechanism, the water divider mechanism to route water from the first water outlet into an aquarium, and from the aquarium to the first macroalgal attachment surface.

26. The apparatus for supplying water of claim 1, further comprising positionable dam segments.

27. The apparatus for supplying water of claim 2, wherein the height of the first reservoir structure is adjustable.

28. The apparatus for supplying water of claim 27, wherein the height adjusts telescopically.

29. The apparatus for supplying water of claim 28, wherein the telescopic height adjustment is accomplished with screw threads.

30. The apparatus for supplying water of claim 10, further comprising a hanging means, the hanging means to support the reservoir structure.

31. The apparatus for supplying water of claim 1, further comprising a water pump.

32. The apparatus for supplying water of claim 31, wherein the water pump is internal to the reservoir structure.

33. The apparatus for supplying water of claim 1, further comprising:

an illumination source;

a bracket, the bracket to position the illumination source external to the first reservoir structure such that illumination from the illumination source reaches the first macroalgal attachment surface.

34. An apparatus for supplying water to a macroalgal attachment surface substantially as hereinbefore described with reference to FIGS. 11-13C.

#### Water Pipe Screen Removal

In the previous art waterfall of FIG. 10, when algal growth 520 grew up into water delivery structure 230 (a water pipe)

the growth would clog the water outlet (not shown) and require that the entire structure **230** be removed for cleaning. As shown in previous art FIG. **2**, the entire apparatus needed disassembly, and the water supply source turned off, so that attachment material **240** could be removed and the inside of water delivery structure **230** cleaned out. If that algae scrubber structure were not disassembled, growth **520** would just be pushed further up into the slot in water delivery structure **230**.

FIG. **15A** shows an embodiment **1500** of the present invention which offers a solution to this problem. By modifying structure **230** such that part of the structure itself moves away from outlet **920**, attachment material **240** can be removed and the inside of structure **230** can then be cleaned without disassembly of the algae scrubber and possibly even without turning off the water supply source. Operation is as follows: Water delivery structure **230**, which in this embodiment is a water pipe **230**, is in operating position. It is a perspective view looking through pipe **230**, and the pipe is open on both ends for clarity. In actual operation, one end of pipe **230** is closed and the other end is a water inlet connected to a water supply source. As water enters pipe **230**, the water exits water outlet **920** which is shown as slot **920** at the bottom of pipe **230**. This slot **920** would be similar to the slot (not shown) on the previous art algae scrubber in FIG. **10**, however in FIG. **10** there is no way to enlarge the slot because it is just cut into pipe **230**. The embodiment of FIG. **15A** however includes water outlet structure **1530**, which is shown as part of pipe **230** that has been cut out at water outlet border **1520**. Because water outlet structure **1530** is still in position within, and abutting, water outlet border **1520**, the water outlet structure **1530** defines a portion of water outlet **920**. Water pipe **230** defines the remaining portion of water outlet **920**. And because water outlet structure **1530** cannot move downwards because of tab **1550**, water outlet structure **1530** is locked into a first position by water pressure inside pipe **230**. As water flows down macroalgal attachment surface **241**, surface **241** is illuminated by illumination source **1145** thus causing algal growth on material **240**.

Positioned in outlet **920** is macroalgal attachment material **240** which defines macroalgal attachment surface **241**; material **240** is shown here as a screen hanging down from outlet **920**, and also as mounting blocks above outlet **920** to keep screen **240** from falling. However material **240** could be any shape which fits into outlet **920** securely and allows water to flow out of outlet **920**. Water outlet structure **1530** cannot move downward because of mechanical stops **1550** that are in place, thus water flows out of outlet **920** and down screen **240** into the area of illumination source **1145**.

FIG. **15B** shows water outlet structure **1530** moved upwards to a second position and attachment material **240** removed downwards from pipe **230**. Unlike previous art FIG. **10**, the current embodiment **1500** in FIG. **15B** does not require any disassembly at all; instead water outlet structure **1530** is pushed upwards into pipe **230** via positioning means **1540** which in this case is a hinge. Once outlet structure **1530** is moved upwards to second position, attachment material **240** is enabled to be removed downwards through water outlet border **1520**. No disassembly of structure **230** is required and it is also not required to turn off the water supply source because the water would simply continue to flow down out of water outlet border **1520** into a sump (not shown) below as it was doing anyway. And it can be seen again in FIG. **15B** that attachment material **240** includes the protruding square mounting pegs at the top of material **240**. These protruding mounting portions of material **240** are

enlarged sections of material **240**, possibly just a thickened screen **240**; the square pegs are simply shown to demonstrate how a larger section of material **240** can be used to lock material **240** into position in pipe **230**.

Water outlet structure **1530** and water outlet border **1520** can be any size or shape which, when water outlet structure **1530** abuts water outlet border **1520** in a first position as in FIG. **15A**, secures an upper section of material **240** into pipe **230** such that the majority of material **240** hangs substantially below water outlet structure **1530** and also such that water which exits water outlet **920** is enabled to flow down attachment surface **241**. "Below" is defined herein as the direction water will travel when poured. FIG. **15A** shows water outlet border **1520** and water outlet structure **1530** to be a rectangular cutout of pipe **230**; structure **1530** thus fits into pipe **230** like a door, being held in first (closed) position by a peg, lip or other protrusion **1550** from pipe **230**, and this peg, lip, or other protrusion prevents structure **1530** from moving downwards. Structure **1530** can only move upwards into pipe **230** via positioning means **1540**. Other shapes and sizes of border **1520**, structure **1530**, and positioning means **1540** are contemplated such as structure **1530** being larger than border **1520**, or structure **1530** being weighted to hold itself in a locked downward first position thus requiring no hinge **1540**, or structure **1530** being capable of rotating inside pipe **230** such that rotation in one direction locks material **240** into slot **920** in a first position and rotation in the opposite direction opens slot **920**, or lastly that outlet structure **1530** is actually half of the entire pipe **230** (pipe cut in half lengthwise like a clam shell) with a hinge or other mechanism at the top of pipe **230** thus causing outlet **920** at the bottom to open when the pipe **230** is opened to a second position.

Alternately to moving up into water delivery structure **230**, water outlet structure **1530** might move downwards to its second position, possibly becoming disconnected from structure **230**. One example of this would be reversing the operating direction of positioning means **1540** such that the hinging action is downwards instead of upwards. Hinge **1540** might then be replaced entirely by a peg, lip, or other protrusion which prevents structure **1530** from moving up into pipe **230**, thus allowing structure **1530** to only move down and away from pipe **230**. In this case structure **1530** might be held into an upward operating first position by a releasable latch, or by flexible straps that go around pipe **230**. Or as previously stated, structure **1530** could move rotationally, this time along the outside of pipe **230** much like a larger pipe over a smaller pipe. Any of these positioning means allow water outlet **920** to be opened up and material **240** to be removed for cleaning and un-clogging without requiring any disassembly of the rest of the algae scrubber apparatus as was needed in previous art FIGS. **2** and **10**.

FIG. **16** shows an embodiment **1600** where water outlet structure **1530** is combined with macroalgal attachment material **240**, thus forming a single unified component. Although simply shown "glued" together, they are a smoothly transitioning seamless molded component. Of note in FIG. **16A** is that the positioning means hinge **1540** of FIGS. **15A** and **15B** has been replaced by positioning means pegs **1540** in FIG. **16**. Because pegs **1540** are not attached to pipe **230**, the entire water outlet structure **1530** and attachment material **240** combination can be removed together. However, positioning means **1540** prevents structure **1530** from coming directly out of pipe **230**; instead, structure **1530** must be pushed upwards into pipe **230** and then moved lengthwise inside pipe **230**, and then one end of

39

structure **1530** can be removed downward out of pipe **230** as shown in FIG. **16B**. This single unified component (structure **1530** and material **240**) allows it to be easily molded into one removable part, sized and shaped such that it fits up and locks into pipe **230** yet removes easily for cleaning of material **240** and outlet **920**.

An alternate way of removing unified structure **1530** and material **240** from pipe **230** is to make the unified component with flexible material such as a flexible rubber or resilient plastic. Thus the unified component (structure **1530** and material **240**) could be somewhat compressed like a sponge, and then removed from pipe **230**, and after cleaning could be compressed again and put back into water outlet border **1520** and released so as to allow the unified component (structure **1530** and material **240**) to expand back into a locking position inside pipe **230**.

#### Example Claims—Water Pipe Screen Removal

1. An apparatus for releasably supporting macroalgal attachment material and supplying water to a macroalgal attachment surface, comprising:
  - a macroalgal attachment material defining a macroalgal attachment surface;
  - a water delivery structure defining a water outlet border;
  - a water outlet structure, the water outlet structure movable from a first position to a second position and defining a portion of a water outlet when in the first position.
  - a positioning means, the positioning means to position the water outlet structure in the first position abutting the water outlet border such that the macroalgal attachment material is secured substantially below the water outlet structure and water from the water outlet contacts the macroalgal attachment surface, and further to enable movement of the water outlet structure to the second position such that the macroalgal attachment material may be removed from the water delivery structure.
2. The support and release apparatus of claim 1, wherein the water outlet structure abuts a top inside surface of the water outlet border.
3. The support and release apparatus of claim 1, wherein the water outlet structure abuts a bottom outside surface of the water outlet border.
4. The support and release apparatus of claim 1, wherein the positioning means defines a hinge.
5. The support and release apparatus of claim 1, wherein the water outlet structure slides laterally from the first position to the second position.
6. The support and release apparatus of claim 1, wherein the water outlet structure rotates from the first position to the second position.
7. The support and release apparatus of claim 6, wherein the water outlet structure rotates inside the water delivery structure.
8. The support and release apparatus of claim 6, wherein the water outlet structure rotates outside the water delivery structure.
9. The support and release apparatus of claim 1, wherein the water outlet structure defines at least one panel.
10. The support and release apparatus of claim 1, wherein the water outlet structure and macroalgal attachment material are a single unified component.
11. The support and release apparatus of claim 10, wherein the single unified component is flexible.
12. The support and release apparatus of claim 10, wherein the single unified component can be lifted from the first

40

position to the second position and subsequently rotated and removed through the water outlet border.

13. The support and release apparatus of claim 1, wherein the positioning means defines tabs.
14. An apparatus for releasably supporting macroalgal attachment material and supplying water to a macroalgal attachment surface substantially as hereinbefore described with reference to FIGS. **15A-16B**.

#### Reservoir Slots

While the water pipe screen removal embodiments above are useful for water pipes, an open-top reservoir embodiment described below may make screen cleaning easier because the user can reach into the reservoir from above and remove blockages without removing the screen, and might also be able to remove the screen in an upwards direction instead of downwards, which may help avoid crowded areas of a sump. In addition, surging of water inside of a water pipe during operation (regardless of how the slot is cleaned) often causes more water to flow out of one end of the slot than the other; the large amount of water in a reservoir, by contrast, gives water more time to reduce velocity before going through the water outlet and thus stabilizes the flow from one part of the water outlet to another.

FIG. **14** shows an embodiment **1400** of the current invention which brings together several of the previously described embodiments including a reservoir, pole mount, settlement tray, and adds a drain internal to the pole mount for a very compact apparatus. Pole mount reservoir **410** is here depicted as rectangular with a bottom **1195** which sets on a base (not shown) which can support pole mount reservoir **410** on the floor of a sump (not shown) beneath sump water level **130**. Water is pumped into pole mount reservoir **410** through water inlet **910** where the water then turns upwards and progresses towards reservoir top opening **1410**, which is also the opening of reservoir compartment **1430** of reservoir structure **1460**. The water forms a surface **1420** which is the reservoir compartment **1430** surface level **1420**, and the open space between this water surface level **1420** and the top of the reservoir top opening **1410** is the headspace. This open reservoir structure **1460** allows the user to reach into reservoir structure **1460** to access and clean the top of macroalgal attachment material **240** and water outlet **920** (which commonly clogs with algal growth); this cannot be achieved with the closed water pipe of previous art FIG. **2**. Reservoir structure **1460** and reservoir compartment **1430** are shown here as being substantially the same, however reservoir compartment **1430** could alternately be smaller than reservoir structure **1460**.

Water subsequently exits reservoir compartment **1430** through water outlet **920** and flows down in waterfall fashion over macroalgal attachment material **240** which is secured substantially below water outlet **920**. "Substantially below water outlet" is defined herein to mean that more than half of macroalgal attachment surface **241** is on the side of the water outlet that water will flow towards gravity. "Above" is herein defined to mean a position farther from the center of the earth, compared to another position. The flowing water (not shown) and any elongated algal growth **520** enabled by illumination source **1145** go down onto macroalgal settlement surface **331** of macroalgal settlement tray **330**; the macroalgal growth substantially stays on tray **330** while the water exits tray **330** through drain orifice **820**; this exiting water is represented by arrow **1440**. Drain orifice **820** is connected to a drain pipe (not shown) internal to pole mount reservoir **410**; this internal drain pipe extends down

to drain outlet 1450 where the water then flows back into the sump following arrow 1455. The internal drain pipe keeps the downflowing water separate from the upflowing water inside pole mount reservoir 410 that enters from inlet 910.

In this embodiment 1400, settlement tray 330 is coupled to pole mount reservoir 410, and attachment material 240 is supported by reservoir structure 1460 such that removal of apparatus 1400 from a sump does not alter the positional relationship between attachment material 240 and tray 330. This is important because when attachment material 240 is full of growth 520 which extends down and collects in thick mats on tray 330, having to pull material 240 away from tray 330 causes algal growth 520 to rip apart into at least two portions and often many more pieces which fall into the sump, or clog drain orifice 820, or fall onto the floor of the room where apparatus 1400 is located. By preserving the positional relationship between material 240 and tray 330 when apparatus 1400 is removed for cleaning/harvesting, no broken algal strands travel to the sump or the floor. If desired of course, the user could alternately reach down into reservoir top opening 1410 and pull attachment material 240 upwards if algal growth is not too thick; this is a fast and easy cleaning option although some growth 520 may be scraped off. The water source flowing into water inlet 910 could be turned off before such a cleaning operation. And another option that preserves the positional relationship between material 240 and tray 330 is to attach material 240 to tray surface 331 (or to a separate tray that sets on surface 331 as in FIG. 13A) and enable material 240 to slide out laterally in the direction of arrow 1465. As material 240 slides out of water outlet 920 in this manner, any growth piled up at the bottom of material 240 will be preserved in one piece because tray 330 (or separate tray on top of tray 330) will slide out with material 240. Water outlet 920 will then be open for cleaning.

Reservoir top opening 1410 does not have a lid shown, however a lid may be used which generally would not be air tight; this enables a headspace to develop between opening 1410 and compartment water level 1420. An open reservoir compartment 1430 such as this allows the user to reach into compartment 1430 to clean reservoir water outlet 920, which in this embodiment is a slot with a rigid screen 240 inserted through it. A simple brushing of the top of outlet 920 is usually sufficient to dislodge any macroalgae which has grown up into outlet 920. This is contrasted with the previous art FIG. 2 where lid 290 must be removed, pump 210 turned off, water delivery pipe 230 lifted out, attachment rings 235 cut off, and finally screen 240 removed; then pipe 230 and screen 240 can be removed to be cleaned, and then the parts re-assembled using new attachment rings 235. If brushing the macroalgae off of the orifice slot in previous art FIG. 2 is attempted without disassembly, the algae get pushed further up into pipe 230, often making the blockage worse.

Macroalgal settlement surface 331 defines a plane that is represented by rectangle 1470 which is shown at the same elevation as surface 331 by dotted line 1471. As described in FIG. 5, one of the defining factors of a pole-mount embodiment of the current invention is that water can be supplied to the apparatus from below the apparatus through pole mount reservoir 410, instead of from above the apparatus as in previous art. So by requiring that water delivery structure 410 intersect the plane of settlement surface 331, water can then come from below surface 331 instead of from above it. Furthering this concept is requiring that the water source structure, such as pole mount reservoir 410, actually contact macroalgal settlement structure 330 such as it does

in FIG. 14. Such contact might be a simple weighted tray 330 that sits on a ledge of pole mount reservoir 410, or a releasable mechanism that allows easy detachment of tray 330 from pole mount reservoir 410 such that tray 330 might slide out laterally (for example, in direction of arrow 1465), or tray 330 might be permanently coupled to pole mount reservoir 410 as shown, possibly by being made of the same material as pole mount reservoir 410. Any other attachment mechanism in the art may also be used. And although shown that pole mount 410 transitions to reservoir structure 1460 at the point of intersection with tray 330, the transition could instead be above or below the point of intersection.

FIG. 17 shows an embodiment of the current invention that makes use of reservoir embodiments and screen removal embodiments described above. 1700 is a waterfall algae scrubber that is positioned adjacent to wall 1750 of a sump (not shown but similar to sump 110 of FIG. 1) with the addition of sump wall 1750 (also called a partition) in the middle of the sump such that water can overflow the top of sump wall 1750 from one section of the sump to another section as shown by arrows 1760 and 1770. And if using sump wall 1750 as a support for algae scrubber 1700, no other support needs to be added, including no pole mount, and no shelf. Sump walls or partitions such as 1750 are already included in many types of sumps. Operation is as follows:

Reservoir structure 1460 is positioned adjacent to sump wall 1750 by a mechanism not shown, but the mechanism could be glue, or a hanger or a hook over the top of wall 1750, or a support which sits on the bottom of the sump below sump water level 130, or any other mechanism in the art; the operational water level inside reservoir compartment 1430 is represented by line 1420. Water (not shown) enters compartment 1430 through water inlet 1710; water flowing through inlet 1710 is represented by arrow 1715. Inlet 1710 is on sidewall 1730 of compartment 1430, however inlet 1710 might be on a floor 1740 of compartment 1430. If on a sidewall 1730, inlet 1710 might be above the compartment water level 1420, or might be below water level 1420 as shown. Alternately, water might enter compartment 1430 by overflowing wall 1750 via arrow 1770 and subsequently falling down into compartment 1430 through reservoir top opening 1410, or overflowing via arrow 1760 and subsequently traveling through an overflow capture 1725 which leads to reservoir compartment water inlet 1720. Similar to inlet 1710, the placement of inlet 1720 can be on a sidewall 1730 as shown, and might be below the compartment water level 1420 as shown or above water level 1420. Overflow capture 1725 has an advantage of aggregating overflowing water 1760 from a larger area than compartment 1430 would by itself. Reservoir compartment 1430 is shown in this embodiment as being substantially the same structure as reservoir structure 1460, however reservoir compartment 1430 could be a smaller portion of reservoir structure 1460 such that more of reservoir structure 1460 were used for support or other needs instead of the containment of water.

Once inside reservoir compartment 1430, water then travels down through water outlet 920 which in FIG. 17 is defined by water outlet structure 1530 and floor 1740. As in FIG. 15A, water outlet structure 1530 defines the shape of water outlet 920, and structure 1530 can be positioned on a floor 1740 of compartment 1430 by any suitable type of positioning means (not shown). Although water outlet structure 1530 in FIG. 15A defined one panel 1530, in FIG. 17 structure 1530 defines two panels, each panel 1530 defining a side portion of water outlet 920. This concept of water outlet structure 1530 being comprised of panels 1530, all of

which contribute to defining water outlet 920, can be extended to any number of water outlet structure 1530 panels, each defining a portion of water outlet 920. Water outlet structure 1530 positioning means 1540, which in FIGS. 15A and 15B is a hinge, is instead a groove (not shown) in floor 1740 below panels 1530. This positioning means 1540 allows panels 1530 to simply set on floor 1740 and attachment material 240 can then be lowered through water outlet 920. For removal, attachment material 240 is simply lifted upwards; prior removal of panels 1530 can be performed but is not required because they will be pushed upwards and sideways by the upwards movement of material 240. It is for this reason that panels 1530 are not permanently attached to floor 1740 in this embodiment.

Once water (not shown) has exited water outlet 920, the water then flows down macroalgal attachment surface 241 and is illuminated by an illumination source such as LED 1145 such that macroalgae (not shown) attaches to and grows on surface 241. The water then continues downwards until it reaches the ambient water surface level below which is represented as line 130; if water level 130 is below the bottom of attachment material 240 then the water simply falls off material 240. Lid 1780, shown as a cutaway view, may be used to cover compartment 1430. Compartment 1430 might be an upper section of reservoir structure 1460 as shown, which simplifies the use of lid 1780 because reservoir top opening 1410 is approximately the same size and shape as the upper portion of reservoir compartment 1430. Lid 1780 generally will have a headspace below it, above compartment water level 1420, such that water level 1420 is enabled to vary in height above outlet 920. This non-sealed nature of lid 1780 allows it to be removed by the user for observation of water outlet 920 without altering the flow of water through outlet 920, and this type of in-service observation of the top of outlet 920 is not possible with a sealed water pipe.

In order to obtain uniform flow of water in the reservoir compartment and thus through outlet 920, a taller compartment 1430 can be utilized so that compartment water level 1420 can be increased; this will keep uneven flow (waves) at water surface level 1420 farther away from water outlet 920 and will allow a more uniform flow out of water outlet 920 to provide attachment surface 241 with more uniform water coverage, instead of some areas with high flow and other areas with low flow as often happens with previous art water pipes where water shoot towards the end of the pipe slot. A problem with these previous art water pipes (as in FIG. 2), especially when there was not yet any growth on the screen, was that the water pressure inside the pipe forced most of the water to the end of the pipe, and thus most of the water flowed out only at the end of the slot; the other end of the slot received little or no flow; the present embodiment of FIG. 17 allows the water movement to slow down and stabilize before exiting outlet 920. A reservoir compartment water surface level 1420 of at least 3 cm will suffice for small algae scrubbers 1700 with slow water flow, however larger algae scrubbers with more flow might need at least 4, 5, 6, 7, 8, 9, 10, 12 or 15 cm, and even larger algae scrubbers might need at least 20 cm.

Another way of obtaining uniform water outlet 920 flow is to have a large volume of water in reservoir compartment 1430 relative to the size of outlet 920. The area size of outlet 920 in FIG. 17 is defined on the long sides by water outlet structures 1530 and on the short sides by the cutout in floor 1740 of reservoir compartment 1430, thus forming a rectangle. For example, the long sides are typically the same length as attachment material 240, in this example possibly

15 cm, and the short sides are typically 0.3 cm, for a cross sectional area of 4.5 square cm. And because reservoir compartment 1430 is essentially the same dimensions as reservoir structure 1460 in FIG. 17, specifying a large size for reservoir top opening 1410 essentially specifies a large amount of water above outlet 920 which will be more uniform during larger flows into compartment 1430 and with less variation of flow from one section of outlet 920 to another. A ratio of reservoir top opening 1410 area to water outlet 920 area of at least 15 has shown to be a good minimum, however larger algae scrubbers 1700 with more water flow, especially when the user must reach through top opening 1410 to access material 240, might need ratios of 30, 50, or 100.

Yet another way to define reservoir structure 1460 dimensions in order to provide uniform water flow out of outlet 920 is to state how long water should continue to flow uninterrupted out of outlet 920 once water is turned off from the water inlet 1710 or 1720. The longer time that water can sustain flow out of outlet 920 without being replenished by water from a water inlet, the more water is being held in reservoir compartment 1430 relative to the size of outlet 920. Uninterrupted flow is defined to be water continuing to flow out of all parts of outlet 920 in one continuous horizontal stream without breaking into segments of smaller horizontal streams and without air passing through outlet 920. A time of 2 seconds has shown to be sufficient for smaller algae scrubbers 1700, although larger algae scrubbers with more flow might need 3, 5, 10, 20, 30, 40, 50 or 60 seconds of uninterrupted water flow out of outlet 920 after water input is stopped.

FIG. 18A shows an embodiment where the screen removal and cleaning process of a reservoir is simplified even further. In FIG. 17, after water outlet structure 1530 has been lifted and material 240 removed, the user may want to access underneath reservoir structure 1460 in order to clean algal growth which may have attached there in the sump, but accessing this area may require reaching between many things in a sump, or lifting the entire apparatus 1700 out. FIG. 18A however combines reservoir compartment 1430 and water outlet structure 1530 into a single unified component which in this embodiment is also the entire reservoir structure 1460 such that lifting reservoir 1460 up allows the user access to both the top and bottom of water outlet 920. Thus material 240 might not need to be removed at all from compartment 1430 because the top and bottom of outlet 920 can be accessed and cleaned without doing so. The water inlet of reservoir structure 1460 might be any of the same inlets of FIG. 17 and thus are not shown here. Water and algal growth (not shown) fall onto floor 1830, and growth on attachment surface 241 can be scraped down onto floor 1830 also; water exits transparent containment wall 1810 through drain hole 1820.

FIG. 18B shows reservoir structure 1460 lifted out of transparent containment wall 1810 so that the algal growth collected on floor 1830 can be removed; containment wall 1810 and floor 1830 serve as a box to carry the growth. Compared to FIG. 17, a main difference of FIGS. 18A and 18B is the support structure 1810 which is shown as a simple transparent container 1810 that can also function as a macroalgal growth containment wall 1810. Reservoir structure 1460 abuts and fits onto containment wall 1810 and is held in place by a friction fit, but might instead be held by a lip at the top of structure 1460 or by other common attachment or positioning techniques. Containment wall 1810 might only be one side of structure 1460 such as a single planar supporting wall, or containment wall 1810

might encircle more or all of structure **1460** as it does in FIGS. **18A** and **18B**. Instead of acting as a support, containment wall **1810** might instead simply hang from reservoir structure **1460**, for example if structure **1460** were supported by some other means. In this case containment wall **1810** might not have floor **1830**, and water flowing down macroalgal attachment surface **241** would simply fall off of the bottom of surface **241**. And because containment wall **1810** can be transparent or translucent, or opaque with illumination ports, illumination from illumination source **1145** reaches attachment surface **241** and enables algal growth to occur. Illumination source **1145** might alternately be inside of containment wall **1830**, possibly mounted onto an internal surface of containment wall **1830** thus allowing containment wall **1830** to be opaque to substantially contain illumination.

Because attachment material **240** can remain coupled to water outlet structure **1530** when the top and bottom of water outlet **920** are accessed for cleaning, a cost saving manufacturing embodiment might be to combine water outlet structure **1530**, reservoir structure **1460**, and attachment material **240** into a single unified component. FIG. **18B** shows that when water outlet structure **1530**, reservoir structure **1460**, and attachment material **240** are lifted out of containment wall **1810** they can essentially be one molded part that gives full access to the top and bottom of water outlet **920** (not visible in FIG. **18B**) and yet still provide the flow stabilizing benefits of a reservoir **1460**. A last option for simplicity might be if the entire structure of FIG. **18A** were a single unified component. With the possible exception of floor **1830**, a single transparent or translucent structure could perform the functions of reservoir structure **1460**, reservoir compartment **1430**, water outlet structure **1530**, macroalgal attachment material **240**, and growth containment wall **1810**. If the upper portion of the structure could be made or painted opaque, possibly black, then the water outlet could be shielded from illumination source **1145** while the attachment material **240** could still receive illumination. And if the illumination source were internal to growth containment wall **1810**, then the entire unified structure could be opaque.

#### Example Claims—Reservoir Slots

1. An apparatus for supporting macroalgal attachment material and supplying water to a macroalgal attachment surface, comprising:
  - a macroalgal attachment material defining a macroalgal attachment surface;
  - a reservoir structure defining a reservoir compartment, a reservoir top opening, and a water outlet on a floor of the reservoir compartment;
  - a macroalgal attachment material positioning mechanism, the macroalgal attachment material positioning mechanism to position the macroalgal attachment material substantially below the water outlet and to align the macroalgal attachment surface such that water flowing out of the water outlet contacts the macroalgal attachment surface.
2. The apparatus for supporting macroalgal attachment material of claim 1, further comprising a water inlet to the reservoir compartment.
3. The apparatus for supporting macroalgal attachment material of claim 2, wherein the water inlet is located on a side wall of the reservoir compartment.
4. The apparatus for supporting macroalgal attachment material of claim 2, wherein the water inlet is located below the reservoir compartment water surface level.

5. The apparatus for supporting macroalgal attachment material of claim 2, wherein the water inlet is located on a floor of the reservoir compartment.
6. The apparatus for supporting macroalgal attachment material of claim 2, wherein the water inlet is located above a water surface level of the reservoir compartment.
7. The apparatus for supporting macroalgal attachment material of claim 2, wherein the water inlet is the reservoir top opening.
8. The apparatus for supporting macroalgal attachment material of claim 6, wherein water falls down into the reservoir top opening.
9. The apparatus for supporting macroalgal attachment material of claim 8, wherein the water is overflowed from a wall.
10. The apparatus for supporting macroalgal attachment material of claim 9, wherein the reservoir structure is coupled to the wall.
11. The apparatus for supporting macroalgal attachment material of claim 2, wherein the water inlet (**1720**) passes through the reservoir top opening.
12. The apparatus for supporting macroalgal attachment material of claim 11, wherein the water inlet (**1720**) extends substantially to a floor of the reservoir compartment.
13. The apparatus for supporting macroalgal attachment material of claim 1, further comprising:
  - a water outlet structure;
  - a water outlet structure positioning means, the water outlet structure positioning means to position the water outlet structure such that the water outlet structure defines a portion of the water outlet.
14. The apparatus for supporting macroalgal attachment material of claim 13, wherein the water outlet structure is releasably coupled to the macroalgal attachment material.
15. The apparatus for supporting macroalgal attachment material of claim 13, wherein the water outlet structure and the macroalgal attachment material are a single unified component.
16. The apparatus for supporting macroalgal attachment material of claim 13, wherein the water outlet structure is moveable from a first position for operation to a second position for removal of the macroalgal attachment material.
17. The apparatus for supporting macroalgal attachment material of claim 16, wherein the second position is above the first position.
18. The apparatus for supporting macroalgal attachment material of claim 13, wherein the water outlet structure defines at least one panel.
19. The apparatus for supporting macroalgal attachment material of claim 13, wherein water outlet structure positioning means defines a hinge.
20. The apparatus for supporting macroalgal attachment material of claim 1, further comprising a macroalgal growth containment wall, the macroalgal growth containment wall configured to abut the reservoir structure.
21. The apparatus for supporting macroalgal attachment material of claim 20, wherein the containment wall includes an illumination source.
22. The apparatus for supporting macroalgal attachment material of claim 20, wherein the containment wall supports the reservoir structure.
23. The apparatus for supporting macroalgal attachment material of claim 20, wherein the containment wall is releasably coupled to the reservoir structure.

24. The apparatus for supporting macroalgal attachment material of claim 20, wherein the containment wall substantially surrounds the macroalgal attachment material.
25. The apparatus for supporting macroalgal attachment material of claim 20, wherein the reservoir compartment, water outlet structure, and macroalgal attachment material are a single unified component.
26. The apparatus for supporting macroalgal attachment material of claims 13 and 20, wherein the reservoir compartment, water outlet structure, macroalgal attachment material, and macroalgal growth containment wall are a single unified component.
27. The apparatus for supporting macroalgal attachment material of claim 1, wherein a reservoir compartment water surface level height is at least 3 cm above the water outlet.
28. The apparatus for supporting macroalgal attachment material of claim 1, wherein a ratio of a reservoir top opening area to a water outlet area is at least 15.
29. The apparatus for supporting macroalgal attachment material of claim 1, wherein the reservoir compartment holds enough water to sustain water flow out of the water outlet for at least 3 seconds when no water enters the reservoir compartment.
30. The apparatus for supporting macroalgal attachment material of claim 1, wherein the macroalgal attachment material is 2-sided.
31. An apparatus for supporting macroalgal attachment material and supplying water to a macroalgal attachment surface substantially as hereinbefore described with reference to FIGS. 14 and 17-18.

#### Illumination Devices

An embodiment of the present invention describes a low cost and easy to manufacture illumination apparatus which has no metallic components in contact with water, and further describes a method for encapsulating illumination emitters by utilizing essentially a single step. Reducing the encapsulation process of illumination devices to essentially a single step allows the cost of the final product to be low enough for small aquarium owners, and by being completely encapsulated with no metallic components in contact with water, the method and apparatus provide the highest corrosion protection for the illumination emitter as well as the highest safety for aquarium livestock. Applicant's GEM™ lights are examples of such devices. Following are definitions specific to the present methods and apparatuses for illumination devices:

**Illumination Emitter:** A source of illumination that has electrical input such as wires, and also produces heat, and also must be protected from water and moisture. Illumination Emitters are commonly light emitting diodes (LED) but could be other electrical devices.

**Overmold:** Thermally conductive and electrically insulative encapsulation thermoplastic or thermoset resin that is placed or poured into a mold cavity around an illumination emitter, lens, and electrical power cable. When solidified, the overmold becomes the outer casing of the illumination apparatus, and although it can be placed or poured in more than one step by allowing a previously placed or poured resin to substantially solidify first, it is preferred to have a single placement or pouring to reduce labor and time costs. Overmold and overmolding are the actions of making an overmold.

**Lens:** A substantially optically transparent or translucent material that covers and protects an illumination emitter. The

lens may be comprised of several different layers including an innermost layer in contact with the emitter itself, and an outermost layer in contact with ambient air or water, and the lens may also be buoyant or have a buoyant attachment to assist with encapsulation positioning.

**Ambient:** Surrounding air or water where the illumination apparatus is to be operated. The air is commonly the air in an enclosed cabinet and generally can be as high as 38 C, and the water is commonly the water in an aquarium or sump and can be as high as 32 C or a seaweed cultivator which can be as high as 45 C. Heat from the illumination emitter is transferred to the ambient.

**Pre-Mold Structure:** A non-metallic substantially rigid component which includes the illumination emitter and lens, and optionally any braces or floats or other components necessary for positioning the illumination emitter in a mold cavity prior to placement or pouring of the overmold.

**Mold Cavity:** The concave portion of a mold that is filled with overmold encapsulation thermoplastic or thermoset resin.

**Brace:** A substantially rigid component internal to a mold cavity which holds a pre-mold structure in position until the overmold can be placed or poured and subsequently solidified; the brace may be part of the pre-mold structure or a separate component. The brace becomes embedded within and thus part of the resulting solidified overmold.

**Fill Level:** The uppermost surface level of liquid resin after it is poured into a mold cavity. The fill level cannot be above the top of a mold cavity; above the fill level is ambient air.

**Outer Perimeter:** The outermost locations of a mold cavity that overmold material will flow into and solidify, up to and including the fill level.

**Holding Force:** A force which holds the pre-mold structure in position until the overmold is solidified. The holding force may come from a holding device, van der Waals forces, magnets, or other sources.

**Holding Device:** A device external to the pre-mold structure and resultant overmold, which holds the lens and thus the pre-mold structure in position until the overmold material is placed and solidified. The holding device may attach to a lens temporarily by suction, adhesive, van der Waals forces, or any combination of these.

**Lens-Mold Interface:** A location in a mold cavity where a lens is positioned in contact with a wall of the cavity. A lens may be held in position at a lens-mold interface by an external force, or may be adhered to the lens-mold interface with a temporary adhesion technique such as van der Waals force or a removable or dissolvable adhesive.

**Lens Outer Surface:** A surface of the lens, which after molding of the illumination emitter is completed, is exposed to ambient and thus allows illumination to travel from the illumination emitter to the ambient.

**Substantially Not Covered By Resin:** A state of cleanliness after molding, wherein a lens outer surface does not require a substantial machining step to remove residual thermoplastic or thermoset resin; any residual plastic or resin can be easily removed by hand wiping.

**No Heat or Moisture Damage:** Ability of an illumination emitter to operate continuously for at least six months without failing due to heat or moisture.

**Bond Line:** Area on an outer perimeter of a resultant overmold that is in contact with ambient air or ambient water, where the overmold thermoplastic or thermoset resin is in contact with another material. The other material may be a lens, brace, electrical power cable, or another portion of thermoplastic or resin which had previously solidified. Bond

lines should be minimized in order to reduce pathways for moisture to enter, and can be expressed as a bond line ratio defined further below. A bond line should not be confused with a mold line, which is the result of separation of a two-part mold of a single pouring of liquid resin.

Substantially Non-Metallic: Will not corrode in long term usage in freshwater or saltwater.

Substantially Electrically Non-Conductive: Electrical resistance of at least  $10^{12}$  ohm-cm.

Substantially Thermally Conductive: Thermal conductivity of at least 0.5 w/mk.

Substantially Encapsulated: An illumination emitter surrounded and contained on all surfaces except for its lens, electrical power cable, and any braces.

The difficulty of encapsulating an illumination emitter in a low cost manner is the number of manufacturing steps needed, especially the number of steps of overmolding because these steps require the handling of liquid plastic that must be allowed to solidify, and if a thermoset resin is used it must sit undisturbed for hours at a time in order to cure. The seemingly simple process of mixing and pouring a base layer of resin, allowing it to cure, then placing illumination emitters and lenses on it and subsequently mixing and pouring more resin over it and allowing it to also cure, is at least twice the number of overmolding steps as a single pouring. This can greatly increase the cost of the final product due to high labor costs of overmolding which are sometimes the highest cost of the product. A second difficulty is water ingress, because a two-step overmolding process leaves a bond line all the way, or substantially all the way, around the overmold thus increasing the potential pathways for moisture to enter.

In particular, trying to encapsulate an illumination emitter with a single step of mixing and pouring thermoset resin proves difficult because there is nothing to hold the emitter in position (no bottom supporting layer of cured resin) while allowing the newly poured resin to solidify. If not held in place the emitter will sink to the bottom of the mold cavity and will be exposed to ambient air or water when removed from the mold. If a pedestal or pins are used to position the emitter during curing, they will become part of the overmold and will add additional bond lines and thus potential water pathways, not to mention that if a pedestal is not heat conductive itself then it will partially block heat removal from the emitter. Multi-part molds, for example with two halves which are split apart after curing, do not help because the emitter must still be held in position during the curing so that the emitter does not touch any of the outer perimeters. The present invention proposes to hold the emitter in position via the lens. While being a delicate part of an illumination apparatus, it might seem that the lens would not be a good place to manipulate the emitter, yet it turns out that because of the large size and relatively flat lenses needed for macroalgal photosynthetic growth usage (very wide optical dispersion), the lens has enough surface area to allow it to support a high power emitter via only non-permanent manipulating forces. Since these forces simply let go during demolding, they do not require an additional disassembly machining step, and further do not leave anything remaining inside the overmold material itself.

The basis of the illumination apparatus functionality of the present invention is the cured overmold. The material which makes up the overmold may be a thermoplastic such as ABS or PET, or a thermoset resin such as epoxy or polyurethane. The plastic will generally need a thermally conductive filler to be added such as boron nitride or aluminum oxide (alumina). The bright white color of these

two fillers in particular adds to the optical reflectivity of the overmold, especially if the overmold is shaped into a dish for illumination reflection; however the true usefulness of these fillers is their ability to conduct heat without conducting electricity. Thermal conductivity of the cured plastic should generally be greater than 0.5 w/mk (watts per meter-kelvin), and preferably greater than 1.0 w/mk, and more preferably greater than 1.5 w/mk, and most preferably greater than 2.0 w/mk, and electrical insulation of the cured resin should generally be greater than  $1 \times 10^{12}$  ohm-cm. A higher thermal conductivity will allow a smaller overmold to be used, thus reducing size and cost. So instead of having several sections of the illumination apparatus for different functions (thermal, electrical, casing), a single overmold material performs all the functions. This is what allows for a low cost consumer product.

A desire of the present invention is to reduce the cost of the final consumer product further by reducing the overmolding steps to just one. While there are many steps to manufacturing an illumination apparatus (such as soldering, etc), the application of an overmold is time consuming, and the application of a thermoset resin in particular requires long curing times and can pose the largest cost in time and labor. Automated injection molding and other methods can be used but they don't overcome the need to hold the emitter in place during overmolding. A feature of the present method invention is easily-detachable pre-mold lens positioning, whereas a feature of the present apparatus invention is an emitter overmold with no bond lines except for the required bond line for the lens and possibly the electrical power cable. This is accomplished by positioning the emitter by using a force on the lens itself.

FIG. 19 shows a perspective partial-cutaway view of an embodiment **1900** of the present apparatus invention, and end result **1900** of the present method invention using overmold **1911**. **1900** is a completely sealed illumination apparatus, in this case utilizing a red 660 nanometer color LED **1913** (light emitting diode) for the illumination and photosynthetic growth of macroalgae, however LED **1913** could be any illumination emitting device. Most illumination devices which create their own illumination will use electricity and thus need protection when exposed to water; LED **1913** is therefore sealed to lens **1914** via lens attachment **1912** which might be any commercially available transparent or translucent sealant, encapsulant or potting material, and might be a very thin layer of 0.1 mm or a much thicker layer as shown. By filling the area between LED **1913** and lens **1914** with a sealant such as lens attachment **1912**, water ingress is further prevented should moisture enter overmold **1911** from the top near lens **1914**. Illumination from LED **1913** travels through lens attachment **1912** and subsequently enters lens **1914**, and after traveling through lens **1914** illumination enters the surrounding ambient air or water (not shown). LED **1913**, lens attachment **1912**, and lens **1914** together comprise a "pre-mold structure" which is assembled before the step of applying overmold **1911**.

Lens attachment **1912** and LED **1913** are surrounded and sealed by overmold **1911**. Overmold **1911** protects LED **1913** from moisture ingress from ambient water immersion, and also conducts heat away from LED **1913** into the ambient air or water, and further becomes the outer shell or casing for the final apparatus **1900**. Overmold **1911** is made of an epoxy resin with aluminum oxide (alumina) powder filler added to the resin before curing, however other thermally conductive and electrically insulating fillers could be added such as boron nitride powder or diamond powder.



Aluminum oxide is useful because of its low cost and generally white color which reflects more light, and boron nitride because of its very high thermal conductivity, brilliant white color, and low weight. Thermoset resins such as epoxy and polyurethanes generally are very water resistant, and epoxy can be very heat resistant also. These resins by themselves (without filler) however, are low in thermal conductivity (generally about 0.12 w/mk) and are generally translucent; thus the addition of filler converts these resins into thermally conductive, electrically resistive, rigid white structures. Injection molding of overmold **1911** using thermoplastics is also possible, however further description below will focus on thermoset resins which are poured while in a liquid state and which solidify (cure) thereafter.

Preventing water and moisture ingress to LED **1913** is of primary importance, and thus the structure of overmold **1911** is as important as the material itself. Any seam, crack, fissure or other non-sealing part of the structure of overmold **1911** might enable moisture from the ambient to reach LED **1913**, and thus the minimization of assembly steps or components which introduce possible seams, cracks, or fissures is best. If overmold **1911** material itself is assumed to be essentially a moisture barrier, then the possible points of entry for moisture will be bond lines **1915** and **1917**. A bond line is where two materials are mated together in a permanent fashion, and in the example of submersible overmold **1911** the bond lines should be completely waterproof, including the prevention of slow moisture creep that may occur with temperature fluxuations over several months. Bond line **1917** is relatively small, located where electrical power cable **1916** enters overmold **1911**; it is usually only a few millimeters in circumference. Bond line **1915** however has a length which is much longer, traveling all the way around lens **1914** where lens **1914** is adhered to overmold **1911**. Bond line **1915** also has a depth defined as the distance from the top outer surface of overmold **1911** down to lens attachment **1912**. As long as these bond lines (**1915**, **1917**) are waterproof, LED **1913** should remain free of moisture ingress. Reducing the length of the bond lines (**1915**, **1917**) will correspondingly reduce the opportunity for seams, cracks, or fissures to be present; reducing the size of lens **1914** will help accomplish this. A problem arises however in how to manufacture apparatus **1900**, because LED **1913** is "floating" in overmold **1911** and thus becomes difficult to position properly when overmold **1911** is being poured (as a liquid) and hardened. By "floating" it is meant that there is no bracket to hold LED **1913** while overmold **1911** solidifies because any such bracket would introduce a bond line which might allow moisture ingress.

**1913A** shows LED **1913** by itself in a side view. **1918** is the top or front of LED **1913**, and **1919** is the bottom or back of LED **1913**, and **1920** (the domed section) is the area where illumination is emitted. For maximum thermal heat transfer from LED **1913** to overmold **1911**, heat should be extracted from both the front **1918** and back **1919** of LED **1913**. However because lens-attachment **1912** is generally not heat conductive (transparent materials, except diamond, conduct heat poorly), this would necessitate lens-attachment **1912** being smaller than shown so that overmold **1911** would cover a substantial portion of the front of LED **1913**.

FIG. **20** show shows a previous art waterproof illumination apparatus **2000** manufactured by a common 2-layer encapsulation technique. In previous art techniques such as this, a first encapsulant layer **2023** was first poured or placed into position. This may have been done by a first pouring of a thermoset resin such as polyurethane or epoxy, or by a first injection molding of a thermoplastic. It may also have been

done by simply placing a pre-molded and pre-solidified part **2023** into position. The LED and lens-attachment was then put into position on top of first layer **2023**. Second encapsulant layer **2022** was then molded on top of first encapsulant layer **2023**; this second encapsulant layer may also have been a poured thermoset resin, and was probably an opaque thermally conductive material. This created a very long bond line **2021** all the way around the illumination structure, and was the largest bond line of the entire illumination structure which allowed for a much greater chance of seams, cracks, or fissures especially if there was any flexing of the overmold during mounting or heating. This was in addition to the fact that it required at least two separate molding steps compared to the single step of the present invention. Thus these previous art techniques not only added to the manufacturing steps and costs but also increased the failure rate. A goal of the present invention is to allow full encapsulation of the illumination emitter in a single step and to do so without a bond line between encapsulation layers.

FIG. **21** shows components of the current invention before the overmolding step. **2131** is a mold for pouring resin into; it is a standard flexible mold made with silicone rubber, but could be any other mold making material. The front of mold **2131** is sectioned off so as to show the inside of mold cavity **2132** more clearly. The top of mold **2131** is the same as the top of the mold cavity **2132** in this embodiment, and becomes the maximum "fill level" outer perimeter which is the maximum height that liquid resin can be filled up to in the cavity **2132**. The dimensions of mold cavity **2132** are defined by side walls **2133** and bottom **2134**. The illumination emitter in this embodiment is LED **2135** which in this case is a "Chip On Board" (COB) LED strip with aluminum backing (electric cable not shown). Lens **2136** is shaped to compliment the shape of LED **2135** and is a strip of transparent or translucent acrylic; lens **2136** might be attached to LED **2135** via a very thin 0.1 mm layer of transparent silicone or urethane. Since LED **2135** and lens **2136** are long and narrow in this embodiment, it can be helpful if they are somewhat flexible so as to minimize potential cracking if the user flexes it. Float **2137** and brace **2138** are also shown before attachment to lens **2135**. Buoyancy floats **2137** might be used if the fill level is more than a centimeter deep, whereas braces **2138** might be used if the fill level is less than a centimeter deep. Taken together and when assembled, LED **2135**, lens **2136**, floats **2137**, and braces **2138** form a pre-mold structure which is then lowered into mold cavity **2132**.

FIG. **22** shows the components of FIG. **21** assembled and ready for resin to be poured into mold cavity **2132**, but with the addition of optional holding device **2242**. The front of mold **2131** is sectioned off so LED **2135** and lens **2136** can be seen in molding position. Optional holding device **2242** is an external substantially rigid device which releasably attaches to the pre-mold structure, primarily by attaching to a portion of lens **2136**; the device **2242** does not subsequently become part of the resulting overmold like float **2137** or brace **2138** does; instead holding device **2242** releasably adheres to an outer surface of lens **2136** or other section of the pre-mold structure which does not become covered with resin. Such releasability might be accomplished with water soluble glue such as PVA (polyvinyl acetate, e.g. "Elmer's glue"), or a suction cup, or van der Waals forces which result simply by pressing a soft surface such as vinyl to a rigid lens **2136** surface. The holding of the pre-mold structure by holding device **2242** allows resin to be poured into mold cavity **2132** in a single pour and thus without any bond lines between multiple layers, because

there is only one layer. When holding device 2242 is utilized, it probably will not be necessary to utilize floats 2137 or braces 2138. Holding device 2242 does require attachment and detachment to lens 2136, as well as an external anchor somewhere outside of mold cavity 2132.

If holding device 2242 is not utilized, then the present invention can utilize floats 2137 or braces 2138 or other positioning mechanisms. Braces 2138 are shown extending downwards and sideways; this disposes the pre-mold structure approximately in the center of mold cavity 2132 laterally, and at the top of mold cavity 2132 vertically, such that poured resin fills beneath and to the sides of the pre-mold structure, especially LED 2135 and lens 2136. Braces 2138 will subsequently become part of the cured (solidified) overmold and will contribute bond lines 2241 at outer perimeters where brace 2138 contacts wall 2133 of mold cavity 2132. However these bond lines can be exceeding small due to the pinpoint contact point of brace 2138, and may be as little as 4 mm in circumference, or about 1 square mm in area, thus making it the smallest bond line in the illumination apparatus. The total length of bond lines on the outer surfaces of the overmold should be minimized, and can be expressed as a ratio of total length of bond lines to total surface area of the outer surface of the overmold; this is termed the "bond line ratio".

For example, if mold cavity 2132 is 170 mm long, 30 mm wide, and 20 mm high, once demolded the entire illumination structure would have an approximate external surface area of 18,200 square mm assuming that the height of lens 2136 above the overmold is negligible. Thus a 1 square mm contact point 2241 would have a bond line length (circumference) of 4 mm, and when occupying 8 separate contact points (4 for each brace 2138), would total about 32 mm of bond line. These 8 contact points 2241 would then have a bond line ratio of  $32/18200=0.0018$  which is a very small value and would offer minimal moisture entrance area compared to the bond line of the lens 2136 itself. However more or larger brace contact points 2241 might be used to provide more support for larger, longer, heavier, or more complex illumination emitters 2135 and lenses 2136, and thus contact points 2241 might have a bond line ratio of 0.002, or 0.01, or 0.1 not including bond lines of lens 2136 or the electrical power cable (not shown). Braces 2138 could alternately extend downward only, which would eliminate the bond lines 2241 on side walls 2133; in this case the weight of the pre-mold structure would push down on braces 2138 causing a friction fit with bottom surface 2134 of mold cavity 2132 which would hold lens 2136 in position as the poured resin cured. If points of entry of moisture are desired to be minimized even further, floats 2137 could be utilized instead of braces 2138; when used without additional positioning structures, floats 2137 become encapsulated entirely and leave no bond lines at all, and require no post-cure holding device removal. Floats 2137 are made of closed cell foam, but could be a sealed canister or balloon. Positioning of the pre-mold structure during pouring and curing could alternately be via magnetism, for example a small magnet (not shown) disposed next to floats 2137; an external magnet or metal bar could then hold the pre-mold structure in position without physically contacting the structure. This small magnet would then become encapsulated with float 2137. Or a small magnet (not shown) could simply be set on top of lens 2136; as long as the magnetism from the external magnet or metal bar were not too strong, the small magnet would stay in position on lens 2136 by friction, and the pre-mold structure would then still be positionable, and the small magnet easily lifted up off of lens 2136 after molding.

FIG. 23 shows the mold cavity 2132 of FIG. 22 filled with resin 2353; the front of mold 2131 is again sectioned off so LED 2135 and lens 2136 can be seen in position with poured resin 2353 which cures to form overmold 2353. Of particular interest in this figure is fill level 2351 which is defined by the top of mold cavity 2132 and thus becomes an outer perimeter of the upper portion of poured resin overmold 2353. A thicker lens 2136 would protrude farther up out of resin 2353 thus allowing illumination to be refracted differently, however bond line thickness 2354 of lens 2136 would not be affected. In order to increase bond line thickness 2354 (thus increasing water resistance), fill level 2351 would need to be increased (raised upwards), however this would overflow mold cavity 2132 and/or spill onto lens outer surface 2352, thus a taller mold cavity 2132 would be needed. Alternately, instead of a taller mold cavity 2132 the pre-mold structure could be placed into a lower position than shown before pouring resin 2353, by adjusting the positioning of the holding device, braces or floats (all not shown). The top 2355 of LED 2135 is shown in partial contact with overmold 2353. Some LED 2135 devices generate substantial heat on this top 2355 side of LED 2135 and therefore benefit by a larger contact area between top 2355 and poured resin overmold 2353. Obtaining this overlap with overmold 2353 with a single layer/pour of encapsulant resin is not easily done without the lens positioning techniques of the present invention.

FIG. 24 shows a cured and finished illumination apparatus 2400 (electric cable not shown) demolded; the front of cured overmold 2461 is sectioned off so LED 2135 and lens 2136 can be seen. Any internal floats or braces are no longer visible in cured overmold 2461, and any external positioning devices have been removed. Note there are no bond lines at all except for one required for lens 2136; any bond line for an electric cable would be negligible compared to the lens 2136 bond line. It is envisioned that a transparent or translucent layer of resin (not shown) could be applied to the top of the entire overmold 2461 including lens 2136 in order to provide additional protection from moisture ingress through the lens 2136 bond line, however there are no low cost transparent or translucent resins or thermoplastics available which are also thermally conductive more than 0.5 w/mk and therefore this extra sealing layer will provide undesired thermal insulation on the top of overmold 2461 which will need to be accounted for, in addition to requiring an entire extra overmolding step and possibly and extra day of curing. This underscores the importance of the ability to provide the required physical, thermal, electrical, optical and sealing properties in a single overmolding step.

Apparatus 2400 is shown as having been made with long rectangular LED 2135 and long rectangular lens 2136, however it is envisioned that LEDs with smaller and more concentrated illumination output areas be used such as LED 1913 in FIG. 19. The side view 1913A in particular shows that the domed area 1920 where illumination is emitted from would require a much smaller lens 2136 in FIG. 24; this small lens could be a simple transparent or translucent coating applied to dome 1920 before encapsulation. For example common 3 watt power LEDs surface mounted to star shaped printed circuit boards (pcb's) as shown in FIG. 19 typically have a domed or flat illumination emitting area 1920 of about 5 mm in diameter which is only about 16 mm in circumference. The long rectangular LED 2135 and lens 2136 in FIG. 24 in comparison might typically be 6 watts, 150 mm in length, and 10 mm in width, giving a circumference (and bond line) of 320 mm. Thus for the same wattage, two of the round LEDs 1913 would give a total

bond line of 32 mm compared to one long rectangular LED 2135 which would have a 320 mm bond line. This 10-to-1 reduction of bond line distance is very significant.

Example: Using mold dimensions as stated in FIG. 22, the resultant overmold would be 170 mm long, 30 mm wide, and 20 mm high, with an approximate external surface area of 18,200 square mm. A typical round shaped electrical power cord might be 3 mm in diameter, with a bond line distance of about 9 mm. Using a single pouring of resin as described herein, the only bond lines would be from the lenses and the power cord; the long rectangular LED 2135 would give a total bond line of  $320+9=329$ , which gives a bond line ratio of  $329/18200=0.018$  which is nine times higher than for two of the round LEDs 1913 whose total bond line is  $32+9=41$  and thus whose bond line ratio would be  $41/18200=0.002$

Adding a second overmold layer adds a 400 mm bond line around the overmold. With a long rectangular lens 2136 the total bond line ratio then becomes  $729/18200=0.04$  whereas with two round LEDs the total ratio becomes  $441/18200=0.024$  which again is substantially lower. Adding two braces 2138 of FIG. 21 with pointed tips adds 32 mm of bond line, which increase the total ratio to 0.042 with a long rectangular lens 2136, or 0.003 with two round LEDs. The total bond line ratio including overmold layers, power cables, lenses and braces is preferred to be less than 0.1, and more preferably less than 0.05, and even more preferably less than 0.01, and even more preferably less than 0.005, and most preferably less than 0.001 which can be achieved with a small power cable and a very high output single LED similar in dimensions to LED 1913 but without any braces or second overmold layers. This example size of 18,200 square mm of overmold 2461 could contain more individual round LEDs 1913 and still keep them within operating temperature; 12 watts of total power usage (4 round LEDs) is typical with such a mass of overmold 2461. When operated in air, the external surface temperature of overmold 2461 will generally stay below 50 C while the temperature of the LED surfaces (1918, 1919 of FIG. 19) will generally stay below 60 C which is suitable for long term operation.

FIG. 25 shows an alternate positioning method for pre-mold structure 2571 shown here consisting only of LED 2135 and lens 2136, but facing downwards inside mold 2131. Front of mold 2131 is again sectioned off. Lens 2136 outer surface 2352 (facing downwards) is secured into position onto mold cavity 2132 floor 2134 such that when resin is poured into mold cavity 2132 the resin will substantially not flow beneath outer surface 2352; thus when demolded, outer surface 2352 will be substantially free of resin and will therefore allow illumination to travel from LED 2135 to ambient via the bottom of the resulting solidified overmold. Outer surface 2352 of lens 2136 could be held onto bottom wall 2134 by the weight of pre-mold structure 2571, or by added weight (not shown) on top of pre-mold structure 2571 which would subsequently be encapsulated within pre-mold structure 2571, or by a weak adhesive or mold release gel, or even by simple van der Waals forces that occur from pressing outer surface 2352 against a soft silicone bottom floor 2134 surface. Not only does the positioning technique of FIG. 25 eliminate all floats, braces and bond lines (except for lens 2136 and a power cable), but the resulting demolded illumination apparatus will have its lens 2136 outer surface 2352 in flush alignment with the exterior of the bottom of the overmold, thus allowing the resulting demolded apparatus lens outer surface 2352 to be held flat against transparent aquarium or sump walls without illumination escaping laterally.

FIG. 26 shows another alternate positioning method for molding (again with front of mold 2131 sectioned off), this time for pre-mold structure 2682 shown here consisting of two each of LED 2135, lens 2136, brace 2681, and with the outer surface 2352 of each LED 2135 positioned facing apart, held against side walls 2133 of mold cavity 2132 by braces 2681. Similar to FIG. 25, lens 2136 outer surface 2352 is secured into position on mold cavity 2132 side walls 2133 such that when resin is poured into mold cavity 2132 the resin will substantially not flow onto outer surface 2352; thus when demolded, LED lens outer surfaces 2352 will be substantially free of resin and will therefore allow illumination to travel from both LED 2135 to ambient via the sides of the resulting overmold. And although braces 2681 will be encapsulated with the resulting overmold, they will not add any bond lines to the structure because they do not reach the external surfaces of the mold. Lastly, the pressure or adhesion of the outer surfaces 2352 into side walls 2133 allows pre-mold structure 2682 to remain above bottom floor 2134 without the need to set on floor 2134, and also to remain below fill level 2351; this positioning above floor 2134 and below fill level 2351 means that no part of pre-mold structure 2682 will be exposed to ambient once demolded, except lenses 2136 and a power cable.

FIG. 27 shows another alternate positioning method for molding (again with front of mold 2131 sectioned off), this time with pre-mold structure 2791 which consists here of two each of LED 2135, lens 2136, and vertical brace 2792. Bottom facing lens outer surface 2352 is adhered to or removably attached or weighted to bottom floor 2134 as in FIG. 25, and vertical braces 2792 are sized to position upper facing lens outer surface 2352 slightly above fill level 2351 such that when resin is poured into mold cavity 2132 the bottom facing lens outer surface 2352 is substantially not covered by the resin, and the upper facing lens outer surface 2352 remains above fill level 2351 thus remaining resin-free. Demolding of the cured resin (not shown) will result in an overmold with illumination emitter 2135 lenses 2136 on top and bottom and will have been accomplished in a single resin layer step with no bond lines added other than the required bond lines for the lenses and power cable.

#### Examples Claims—Illumination Devices

1. A water submersible and ambient air cooled illumination apparatus, comprising:
  - an illumination emitter;
  - a lens;
  - an overmold, the overmold being substantially thermally conductive, substantially electrically non-conductive, and substantially non-metallic, the overmold to position the lens to be in optical communication with the illumination emitter and to enable illumination and heat from the illumination emitter to travel to surrounding ambient air or water;
- whereas the illumination apparatus can operate without moisture damage when submerged in water and without heat damage in ambient air.
2. The illumination apparatus of claim 1, wherein a total bond line ratio is less than 0.1
3. The illumination apparatus of claim 1, wherein the overmold substantially contacts a bottom side and a top side of the illumination emitter.
4. The illumination apparatus of claim 1, wherein the overmold is a single layer.
5. The illumination apparatus of claim 4, wherein the overmold has an additional bond line from a brace, the additional bond line not exceeding a 0.002 bond line ratio.

6. The illumination apparatus of claim 1, wherein the overmold substantially contacts a top side of the illumination emitter.
7. The illumination apparatus of claim 6, wherein the overmold is a single layer.
8. The illumination apparatus of claim 7, wherein the overmold has an additional bond line from a brace, the additional bond line not exceeding a 0.002 bond line ratio.
9. The illumination apparatus of claim 1, further comprising a translucent coating which substantially coats both the lens and a top portion of the overmold.
10. The illumination apparatus of claim 9, wherein the coating is transparent.
11. The illumination apparatus of claim 10, wherein the overmold is a single layer.
12. The illumination apparatus of claim 11, wherein the overmold has an additional bond line from a brace, the additional bond line not exceeding a 0.002 bond line ratio.
13. A method for making a water submersible and ambient air cooled illumination apparatus, comprising:
  - placing a pre-mold structure inside a mold cavity;
  - positioning the pre-mold structure such that an outer surface of an illumination emitter lens is positioned at least at an outer perimeter of the mold cavity;
  - placing within the mold cavity a liquid overmold material that is substantially thermally conductive, substantially electrically non-conductive, and substantially non-metallic, such that the outer surface of the lens is substantially not covered by the overmold material;
    - allowing the overmold material to solidify;
    - demolding the solidified overmold material;
 whereas the resulting demolded illumination apparatus can operate in ambient air or submerged in water without moisture or heat damage to the emitter.
14. The method for making an illumination apparatus of claim 13, wherein the outer surface of the lens is above a fill level.
15. The method for making an illumination apparatus of claim 13, wherein the lens is held in position by a holding force.
16. The method for making an illumination apparatus of claim 15, wherein the holding force is van der Waals forces between a mold cavity wall and an outer surface of the illumination emitter lens.
17. The method for making an illumination apparatus of claim 15, wherein the holding force is an external holding device.
18. The method for making an illumination apparatus of claim 15, wherein the holding force is buoyancy.
19. The method for making an illumination apparatus of claim 15, wherein the holding force is magnetism.
20. The method for making an illumination apparatus of claim 15, wherein the holding force is an internal brace.
21. The method for making an illumination apparatus of claim 20, wherein the brace extends to a bottom floor of the mold cavity.
22. The method for making an illumination apparatus of claim 20, wherein the brace extends between at least two separate pre-mold structures.
23. The method for making an illumination apparatus of claim 13, comprising the additional steps of:
  - coating both the lens and the overmold with a liquid translucent coating.
  - allowing the liquid translucent coating to solidify.
24. The method for making an illumination apparatus of claim 23 wherein the coating is transparent.

25. The method for making an illumination apparatus of claim 13, wherein the pre-mold structure includes braces.
26. The method for making an illumination apparatus of claim 13, wherein the pre-mold structure includes floats.
27. The method for making an illumination apparatus of claim 13, wherein the pre-mold structure includes magnets.
28. A water submersible and ambient air cooled illumination apparatus substantially as hereinbefore described with reference to FIGS. 19-27.
29. A method for making a water submersible and ambient air cooled illumination apparatus substantially as hereinbefore described with reference to FIGS. 19-27.

### 3D Printed Macroalgal Attachment Material

The surfaces to which macroalgae attach preferably should be rough and porous so as to allow the algae to hold on without detachment during the rapid water and/or gas bubble flow that is required for enhanced growth. A porous surface allows the attachment points of the macroalgae to hold on better, especially if the orifices which make up the porous network allow the algal cells to circle around back to themselves so that they can form a loop, much like vines wrapping around a trellis will connect back to themselves. Previous work by the applicant in 2008 includes using plastic knitting canvas material roughed up by hand (detailed in applicant's U.S. Pat. No. 9,115,008), and ribbons and rocky textures in applicant's pending U.S. application Ser. No. 14/380,926, both of which are herein incorporated by reference in their entirety. While these previously described attachment surfaces do work well, their manufacture requires a fair amount of labor, such as the roughing of the canvas, or the gluing of the ribbons or rocks. Other available manufacturing techniques such as injection molding come at a high initial price yet are still not able to include extremely thin features which enhance algal attachment, especially "slime" algae attachment. The present invention makes use of current low cost 3D printing technology to solve these issues, and applicant's Green Grabber® algal attachment screens are examples of the results. Following are definitions specific to the present 3D printed macroalgal attachment material methods and apparatuses.

"Solid Polymer"—A polymer (**28120**, **29220**, **29230**) that is below its melting temperature and thus does not flow, although it can still be elastic if mechanical pressure is applied to it. The solid polymer (**28120**, **29220**, **29230**) can be any shape, e.g. a non-porous smooth sheet **28130**; a rough sheet **28120** in which water cannot penetrate; a regular pattern of cross members (**28112**, **28113**) in which water can penetrate; or a random pattern of random shapes, or a regular pattern of repeated shapes. The shapes can be organic or geometric; planar or non-planar.

"Melted Polymer"—A polymer **29248** that is above its melting temperature and thus flows with gravity. Melted polymer can be poured out of a cup. Melted polymer that has cooled enough to become solid **29247** is termed "solidified".

"Heating Element"—A solid object **29210**, usually but not necessarily metal, which can be brought to a high enough temperature to melt a solid polymer (**28120**, **29220**, **29230**). This solid polymer could be the shape of a filament **29220** that comes into contact with heating element **29210**. Solid polymer filament **29220** may enter an orifice in heating element **29210** and exit heating element **29210** in melted state **29248**; this is an established and desired 3D printing methodology. Alternately, heating element **29210** can be made to come into contact with solid polymer **29250**,

causing solid polymer 29250 to become melted polymer 29257. This melted polymer 29257 will often adhere to heating element 29210, and while this does occur frequently, it is usually not desired in 3D printing methodologies because it tends to drag melted polymer 29257 into places where the user does not want it. A heating element 29210 that is not part of a 3D printer may also be used, e.g. a heated object 29210, possibly under computer motion control, which just touches, melts, and then moves melted polymer 29257; this could be thought of as “sculpting” the polymer.

“Layer”—a single thickness of 3D printed solidified polymer 29245 that is attached to a surface 29230, the surface 29230 usually being below layer 29245 or at least below a section of layer 29245. Layer 29245 can be planar as shown in FIG. 29, as is the case in most current 3D melting-filament printers, or layer 29245 could be curved in one or more axes as can be done on “polar” or multi-axis “reticulated arm” melting-filament printers. A 3D printed object 28000 is usually built with many layers on top of each other; the first layer often being attached to a usually planar surface such as a metal or glass “bed” 29270 so as to secure the resulting solidified 3D printed object 28000 in a stationary position while heating element 29210 moves in relation to object 28000. A first layer might be a bottom layer 29245 as shown in FIG. 29000 which is not the bottom first layer of the entire object 28000, but instead is just the bottom first layer of the section where layer 29245 is placed. Additional layers 29247 can then be added to first layer 29245.

“Extrude”—The process of utilizing a melting-filament 3D printer and 3D printer heated nozzle 29210 to push solid polymer filament 29220 into the heated nozzle 29210 such that when the polymer exits nozzle 29210 the polymer 29248 is melted and the moving nozzle can therefore “print” or “lay-down” or “deposit” this melted polymer 29248 onto something below it. If the extruded polymer 29248 is deposited onto a planar surface such as glass or metal bed 29270, then polymer 29248 solidifies and attaches to bed 29270; if the extruded polymer 29248 is deposited onto a previously deposited layer 29245 of polymer, then polymer 29247 welds itself to the previous layer 29245. The resultant deposited and solidified polymer 29247 is an “extrusion”, and this extrusion process is standard in the art. An extrusion 29245 can also done in mid-air if the extrusion 29245 is attached at both ends so as to keep it from falling.

“Hairline Thread”—a very thin cross-section of solidified polymer (28190, 28195), usually less than 0.5 mm in diameter, and sometimes less than 0.1 mm, that is only attached at one or both ends and is otherwise suspended in mid-air. A hairline thread (28190, 28195) can be made by the movement of heating element 29210 from a first location 29275 to a second location 29276 when there is melted polymer 29248 adhered to the outside of heating element 29210; the shape of the hairline thread (28190, 28195) may very well resemble a human hair. When hairline threads (28190, 28195) are made in 3D printing it is sometimes called “stringing”, and this process does not require the 3D printing nozzle 29210 to be extruding at the time that the threads (28190, 28195) are being formed. Hairline threads (28190, 28195) are commonly thinner than the orifice diameter where melted filament 29248 exits nozzle 29210, and thus hairline threads (28190, 28195) cannot be easily extruded directly from such nozzles 29210 because the extruded polymer 29248 would be thicker than desired.

“Bridge”—a section (28160, 29245) of a 3D printed object 28000 which crosses a void (29249, 29280) much like a highway bridge crosses a river. The cross-section of solidified polymer bridge (28160, 29245) is thicker than a

hairline thread (28190, 28195) and is usually greater than 0.5 mm in diameter and is usually several printed layers thick. A bridge (28160, 29245) is attached to sections of solid polymer (29230, 29240) on both ends of the bridge (28160, 29245), and the bridge (28160, 29245) may be of any cross-sectional shape such as round or square or organic (irregular).

“Cross Members”—Main structural sections (28112, 28113) of some types of macroalgal attachment material 28000, often resembling a screen. The area directly between cross members (28112, 28113) is open and herein is called a void. Cross members (28112, 28113) can be formed into the shape of a sheet 28110 resembling a porous screen so water and light can penetrate macroalgal attachment material 28000 thus enhancing photosynthesis. Alternately, cross members (28112, 28113) could be attached to a non-porous sheet 28130 such that water and light cannot penetrate; this is shown by label 28120 where porous screen 28110 is attached to non-porous sheet 28130. Many other shapes of cross members (28112, 28113) are possible besides a screen shape, such as amorphous rock shapes, tree shapes, man-made wall shapes, etc., so long as there is an open void directly between at least two of the cross members (28112, 28113).

“Void”—An open area between solidified polymer such as cross members (28112, 28113), the area having substantially no polymer except possibly for hairline threads 28195. Voids are generally 1-10 mm across, and preferably between 2-7 mm across.

“Polymer Sheet”—A general sheet of polymer 28120, with or without holes or voids, that is smooth planar 28170 or with shapes such as cross members (28112, 28113) or a combination of these. A polymer sheet 28120 can also be just a flat polymer screen 28110 as explained above.

“Lump”—A protruding irregularity 28140 on the surface of an otherwise planar or regular-patterned sheet of polymer (28110, 28120, 28130). Lumps 28140 are generally 1-5 mm in diameter, and extend generally 1-5 mm out from the sheet (28110, 28120, 28130). Lumps 28140 can be created either by the deposition of melted polymer 29248 from a 3D printing nozzle, or by the contact and subsequent moving away of a heating element 29210 with a solid polymer 29250, or a combination of both.

“Bed”—A flat surface 29270 that solidified polymer 29250 is adhered to in melting-filament 3D printing. The bed 29270 can cause a smooth (possibly planar) surface on the bottom 28180 of the printed part 28000, no matter what shape the rest of the printed part 28000 is. A glass bed 29270 especially, can give a mirror-smooth finish on the bottom 28180 of printed part 28000. Such smooth surfaces do not contribute to the ability of macroalgae to attach.

“Porous”—A material having the ability of gas bubbles to at least partially penetrate it without diverting around it, or water to at least partially pour through it without the flowing over the sides of it.

“Non Porous”—A material having the ability to prevent gas bubbles from penetrating it, or water from pouring through it.

Several types of 3D printing methodologies are available, but most are not at the low cost level needed for simple “algae attachment screens”. And the almost universal desire of all 3D printer users is to create the finest detail, using the smallest layer 29245 heights, and with the least artifacts and errors as possible; this makes cost go up even further when fine detail is involved because the printers must run slower and more precise, or use polymer at a reduced rate in thinner layers 29245, thus taking longer to complete. Interestingly,

these very artifacts which users wish to avoid can make a macroalgal attachment surface more effective, and as of December 2015 had not yet been implemented to make very rough macroalgal attachment materials.

In particular, melting-filament printing (called Fused Deposition Modeling (FDM) and Fused Filament Fabrication (FFF) printing) have a “flaw” which turns out to be a benefit for algal attachment: they can have “hairline threads” (28190, 28195, 29257). These hairline threads (28190, 28195, 29257) can occur when the print nozzle 29210 in a FDM/FFF melting-filament printer tries to move the heating element nozzle 29210 in a non-printing (non-extruding) move from a first location 29275 to a second location 29276, but during this move nozzle 29210 leaks melted polymer 29257 when it is not supposed to, or, melted polymer 29248 that is adhered onto the outside of printer nozzle 29210 drags across a previously printed surface. In other words, there are areas 29275 where the nozzle is supposed to print (extrude) melted polymer, and areas 29276 where it is not supposed to, but nozzle 29210 must still move past these non-printing areas 29276 to get to the next area 29277 that needs printing. It’s during these non-printing moves (called “travels”) that undesired hairline threading (28190, 28195, 29257) can occur, and if there are enough of these hairline threads, a 3D printed object can look like it is covered in spider webs.

One explanation for this undesired release of melted polymer (28190, 28195, 29257) is that 3D printing nozzles 29210 have a “melt zone” or “melt pool” inside them which is between the solid polymer filament 29220 (going into the nozzle 29210), and the output orifice (not shown) of nozzle 29210 at its bottom. After printing a first location 29250, nozzle 29210 stops pushing filament 29220 out and then moves to second location 29255 that needs printing; however during this move to second location 29255 the “melt pool” inside nozzle 29210 starts draining out of nozzle 29210, and thus lets out a little bit of melted filament 28195 during this move. So, in between first printed area 29250 and second printed area 29255, this little bit of melted filament causes a hairline thread 28195 to appear between the two areas. Hairline threads 28195 and hairline threading (“stringing”) are normally avoided using many different techniques including:

1. Retracting melted polymer 29248 back into the nozzle 29210 during non-printing travel moves;
2. Reducing nozzle 29210 temperature;
3. Moving nozzle 29210 faster during non-printing travel moves;
4. Wiping nozzle 29210 before non-printing travel moves;
5. Allowing previously-printed layers 29245 to cool more before printing a next layer 29247 on top of it;
6. Reducing overall amounts of polymer 29220 being pushed through nozzle 29210;
7. Reducing bed 29270 temperature;
8. Using PLA polymer.
9. Not allowing nozzle 29210 to travel across previously printed areas;
10. Using a smaller orifice for nozzle 29210.

So interestingly, if you do the opposite of some or all of these techniques, you can encourage hairline threads (28190, 28195, 29257) which will enable better macroalgal attachment because the more places algae can grab on to, the better the algae can grow longer without being washed away by air/water interface turbulence. These techniques are detailed below:

1. A very common technique to avoid hairline threading (28190, 28195, 29257) is to “retract” melted filament 29248 back into nozzle 29210, usually 1-3 mm for direct drive type filament printers, or 5-10 mm for Bowden type filament printers, before a non-printing travel move. Turning off this retraction can cause large amounts of hairline threads (28190, 28195, 29257) especially when the nozzle 29210 is moving across large areas of the printed object.

2. Polymers 29220 used in 3D printing such as ABS tend to start flowing and hairline threading (28190, 28195, 29257) more as the temperature of nozzle 29210 increases, so the usual goal is to reduce nozzle 29210 temperature enough that threading (28190, 28195, 29257) stops but the extrusion process continues. ABS polymer tends to start threading more at 240 C, so increasing the nozzle 29210 temperature above 240 C will generate more of the desired hairline threads (28190, 28195, 29257).

3. Non-printing moves, called “travels”, are usually done much faster than printing, thus nozzle 29210 can get to the new printing location before melted polymer 29248 drains out of nozzle 29210. If nozzle 29210 is printing (moving) at 30 to 60 mm per second across bed 29270, then a non-printing “travel” move is usually more than 100 mm/s. So by not speeding up these non-printing travels, nozzle 29210 will slowly cross over printed areas, enabling melted polymer 29248 to flow out of nozzle 29210 thus cause hairline threads (28190, 28195, 29257). In particular, slowing the travel speed down to 30 mm per second is preferred; 20 mm per second is more preferred, and 10 mm per second is most preferred.

4. Wiping nozzle 29210 is a printing option that causes nozzle 29210 to remove excess melted polymer 29248 from the nozzle 29210 tip/orifice before traveling to the next printing location. It does this by making non-printing moves of nozzle 29210 across an already-printed layer 29230 while in contact with the layer 29230, which then scrapes melted filament 29248 off nozzle 29210. Thus, by turning off this “wiping” feature, more threading (28190, 28195, 29257) will occur.

5. Printed parts 28000 which are about 4 square cm (2 cm by 2 cm) or less cause heated nozzle 29210 to stay very near the same printing location 29230, going back and forth within the 4 square cm area and causing the printed solidified polymer 28160 in that location to stay hot because of the radiated and convected heat from the nearby nozzle 29210. Since the previously-printed layer 29245 in this case can thus still be somewhat melted when nozzle 29210 comes back to print the next layer 29247, previously-printed layer 29245 tends to stick to nozzle 29210 and get dragged around. The usual solution is to use a print-cooling fan (not shown) to blow air onto the just-printed section 29245, or to have nozzle 29210 move far away after each layer for a few seconds, for example about 5 cm, so previously-printed layer 29245 can cool (solidify) before nozzle 29210 comes back for the next layer 29247. Generally if nozzle 29210 can be moved 5 cm away from original part 2 cm by 2 cm part 28000, and stay away for at least 30 seconds, original part 28000 (and original layer 29245) will be solidified and ready for a next layer 29247. So by not allowing this cooling to take place (by not using a cooling fan, or by not moving the nozzle farther away), previously-printed layer 29245 on original part 28000 will still be somewhat melted and will adhere much more to nozzle 29210 and will thus create more threading (28190, 28195, 29257). When printing a large flat algae-attachment screen, this process can be done by computer modeling a screen 28000 in several separate 4 square cm pieces (2 cm by 2 cm squares) that are touching each other, and then instructing the printer to print each square completely (from first bottom layer to last top layer) before moving to the next 4 square cm piece. If external dimensions of nozzle 29210 are narrow enough, and if the adjoining squares are not too many layers tall, then nozzle 29210 will be able to move to the adjacent square and start printing its first bottom layer 29255 without hitting the top layers of the

previous square. This is usually possible because macroalgal attachment materials are often less than 2 mm thick.

6. Allowing too much (called “over extruding”) melted polymer **29248** to be pushed out of nozzle **29210**, compared to the amount needed for proper printing, causes threading (28190, 28195, 29257) because the excess polymer “squeezes out sideways” from below nozzle **29210** and tends to stick to the outside of nozzle **29210** and get dragged around. So, by over extruding purposely, such as by using 10 to 50 percent more polymer **29220** than required for a “proper” print, threading (28190, 28195, 28257) can be obtained. The exact volumetric amounts of polymer flow vary by nozzle **29210** size and printing speed, but all melting-filament printers are calibrated for best polymer flow before printing, so after this calibration for a normal proper print, the extrusion rate can then be increased 10 to 50 percent above this extrusion rate.

7. Temperature of bed **29270** is usually set so extruded polymer has good adhesion of the first layer **29278** to bed **29270**; on subsequent (upper) layers, bed **29270** temperature is sometimes reduced so as to not add extra unneeded heat to the remaining layers that are yet to print. Too much heat from bed **29270** can cause upper layers **29245** to stay melted longer, contributing to threading (28190, 28195, 29257). Commonly the first layer **29278** may print with bed temperatures of 100 C to 110 C for ABS plastic filament, and be reduced to 80 C or 90 C on subsequent layers. So by not reducing bed **29270** temperature, or instead increasing bed **29270** temperature beyond what is needed for good first-layer **29278** polymer adhesion to bed **29270**, more heat will flow upwards. A bed **29270** heat of 130 C for ABS plastic, especially if the entire printed object **28000** is a thin (e.g. 2-5 mm) screen laid flat on bed **29270**, will greatly add to threading (28190, 28195, 29257).

8. Of the two common melting-filament polymers **29220** currently used in 3D printing, PLA and ABS, using PLA will easily print at lower temperatures and do so with little threading (28190, 28195, 29257). So by using ABS polymer filament **29220** instead, and at higher temperatures, more threading (28190, 28195, 29257) will occur. And a newer filament, PETG, is known to have even more threading (28190, 28195, 29257) even when precautions are taken. So by using PETG, threading (28190, 28195, 29257) will be maximized.

9. A printer option called “avoid crossing perimeters” or “combing” causes nozzle **29210** to not cross over outer walls of previously printed locations, and instead keeps nozzle **29210** inside of the outer walls of printed object **28000** so that any threading will disappear inside object **28000** and not be seen outside of final printed object **28000**. So by turning this feature off, and also possibly computer modeling object **28000** such that many non-printing travel moves occur over previously printed areas, threading (28190, 28195, 29257) will be increased. One way to do this computer modeling is to have several different heights of model **28000**, such that they are islands next to, but touching, one another. The height difference of the islands does not need to be great; only one printed layer’s **29245** thickness, which is usually 0.1 to 0.3 mm. The height differences may be invisible to the user but nozzle **29210** will still have to make non-printing travel moves from one island to the next, thus maximizing threading (28190, 28195, 29257) as nozzle **29210** travels over previously printed locations.

10. Smaller nozzle **29210** orifices (not shown) such as 0.2 and 0.3 mm diameter will offer greater resistance to melted polymer **29248** draining out of nozzle **29210** during non-printing travel moves. So by using larger nozzle **29210**

orifices such as 0.4 and 0.5 mm, and especially 0.6 mm diameter, draining will be increased especially on long travel moves. These larger nozzle **29210** orifice diameters will also allow more melted polymer **29248** to be extruded during printing, thus further increasing the amount of polymer that adheres to the outside of the nozzle **29210** which subsequently gets dragged around.

Now is described how to stretch melted polymer **29248** with a heating element so as to form hairline threads (28190, 28195, 29257). The heating element can be a 3D printer nozzle **29210**, or another heated object **29210** that does not extrude, but the stretching of polymer will still occur because of the adhesion of melted polymer **29248** to the outside of heating element **29210**. The direction of hairline threads (28190, 28195, 29257), and contact or non-contact of hairline threads (28190, 28195, 29257) with each other, can be controlled by the direction of travel of the heating element **29210** when stretching the melted polymer **29248**. By having heating element **29210** move in the same direction each time when stretching polymer **29248**, subsequently solidified hairline threads (28190, 28195, 29257) will substantially be in the same direction. And by pausing movement of heating element **29210** during the stretch, melted polymer **29248** that is farther from heating element **29210** is allowed to solidify in a stretched and upwards location **29276** thus reducing the chance of the melted hairline thread **28190** falling down and solidifying onto another hairline thread **28195**. The pause of movement can be from 0.5-5 seconds if no print-cooling fan is used; a print-cooling fan (not shown) will reduce the pause time needed. The advantage of having all hairline threads **28190** substantially in the same direction and non-touching is it allows “comb harvesting”, which is the ability to harvest algae from hairline threads with one motion of a comb-harvesting device without the “comb” getting stuck in and/or damaging hairline threads **28190**. This comb-harvesting is described in detail in co-pending U.S. application Ser. No. 14/380,926 which is herein incorporated by reference in its entirety.

Some applications of algal attachment material **28000** focus on dark slime macroalgal growth, or brown slime growth such as dinoflagellates or diatoms. This type of growth does not attach as well to surfaces the way green hair algae does, and thus needs more “holding” or support from attachment material **28000**. U.S. Pat. No. 8,764,985 by Adey details these supporting mechanisms, and is herein incorporated by reference in its entirety. In these cases of more slime-based algae, the preferred mechanical structure of attachment material **28000** is more of a web of hairline threads (28190, 28195, 29257) that are touching/connected, and thus the preferred direction of hairline threads is non-uniform (e.g., random), especially if the threads **28195** re-attach at their ends, thus forming a supporting “web” for the algae. To make this web of touching/connected hairline threads **28195**, heating element **29210** need only direct it’s movement back and forth over previously solidified hairline threads **28195**.

A furthering of the hairline thread concept is “bridging”. Although thicker than hairline threads (28190, 28195, 29257), bridges (28160, 29245) still allow macroalgae to encircle the bridge (28160, 29245) and attach back to itself. Although bridging is an established and desired technique in 3D printing, it is usually for larger parts of a printed object where the bridge is several centimeters high or long, for example the top of a door in a house model. In contrast, for algal attachment, what is preferred is a large number of very small bridges (28160, 29245) with sizes of the order of 1-5 mm span, with 1-2 mm high passage **29249** below it, such



65

that the passage **29249** created under the bridge (**28160**, **29245**) has a cross sectional area (span times height) less than 10 square mm, and preferably less than 5 square mm. These bridges (**28160**, **29245**) allow algae to stay inside the passage **29249** under the bridge (**28160**, **29245**), and not be removed when the algae is harvested by the user, thus shortening the re-growth time of the next growth cycle because there will still be algae there for growth. The algae stay attached because the small passages **29249** are too narrow to allow cleaning brushes or scrapers to get inside, thus the algae are not brushed away during harvesting. A high concentration of these bridges (**28160**, **29245**) per square centimeter allows maximum algal attachment: At least 2 bridges (**28160**, **29245**) per square cm is desired; more desired is 4 bridges per square cm, and most desired is 8 bridges per square cm. Note that bridges can also be irregular organic shapes, instead of the straight or curved shapes of **28160** as shown.

Another type of stretched melted polymer is a lump. Lumps **28140** are very durable compared to hairline threads (**28190**, **28195**, **29257**) and will resist damage when macroalgae is harvested from macroalgal attachment material **28000**, especially if a mechanical scraper is used such as a rubber scraping tool or stiff brush. Some macroalgae may also be so well-attached to hairline threads (**28190**, **28195**, **29257**) that the threads break off when the algae is harvested. Lumps **28140**, however, are by comparison short and thick, and should resist breakage from most types of macroalgae attachment and harvesting. And the combination of hairline threads (**28190**, **28195**, **29257**) and lumps **28140** provides attachment surfaces for both slime algae (dinoflagellates, diatoms, etc) and the sturdier hair macroalgae (cladophora, ulva, spirogyra, etc) on one attachment material **28000**. Note that lumps can also be irregular organic shapes, instead of the cylindrical shape **28140** shown.

When nozzle **29210** or heating element **29210** contacts solid polymer (**28120**, **29278**) or deposits melted polymer **29248** onto solid polymer (**28120**, **29278**, **29245**), for example at a first position **29277**, melted polymer **29248** adheres to both the solid polymer (**28120**, **29278**) and the nozzle/heating element **29210**. When nozzle/heating element **29210** is subsequently moved to a second position **29276**, a "lump" **28140** will remain on solid polymer (**28120**, **29278**). A hairline string **28190** may also be formed on top of lump **28140**. The lump **28140** is generally larger than the contact area where nozzle/heating element **29210** touches the solid polymer (**28120**, **29278**), especially if nozzle **29210** is extruding melted polymer **29248**. Further, by pausing the movement of the nozzle/heating element **29210** a few millimeters above lump **28140** as the nozzle/heating element **29210** moves away from lump **28140**, the thickness and height of lump **28140** can be altered. This pause may be from 0.5-5 seconds, and may occur from 1-10 mm from the lump, before the nozzle/heating element **29210** then proceeds to the second position **29276**.

One last ability of a purposely "rough-printed" object **28000**, such as applicant's Rough 3D™ technique, is the ability to include grommets **28197** within the rough textures during the printing of printed part **28000**; the grommets **28197** can be used to attach finished object **28000** to water delivery pipes (if a waterfall algae scrubber configuration), spargers (if gas bubble upflow algae scrubber configuration), or other frames (if horizontal river/floway algae scrubber configurations). Not only does this allow grommet **28197** to be covered in the same rough textures as the remainder of object **28000**, but grommet **28197** is stronger because it becomes welded to the screen material during the 3D

66

printing process which also increases production speed because a separate process is not needed to attach grommet **28197** to object **28000**. Although called a grommet **28197**, it can be any shape which allows anchors (not shown) to pass through the object **28000**, and grommet **28197** should be printed thick enough to not rip away from the anchor when the growth surfaces are at their thickest growth. And although shown as circular, grommets **28197** could as well be square or other shapes, and can be positioned in the middle, front or back of material **28000**.

#### Example Claims—3D Printed Macroalgal Attachment Material

1. A method for making macroalgal attachment material, comprising:
  - (i) elevating the temperature of a heating element above the melting temperature of a solid polymer;
  - (ii) moving the heating element to a first location, the first location enabling the heating element to be in mechanical contact with the solid polymer for a sufficient amount of time to melt the solid polymer such that resulting melted polymer adheres to the heating element;
  - (iii) moving the heating element to a second location, the second location not in mechanical contact with the solid polymer of the first location, and the second location being far enough from the first location such that melted polymer that is adhered to the heating element is stretched into a lump;
  - (iv) repeating steps (i) through (iii) in different locations until a desired number of lumps have been produced; whereby the lumps provide attachment points for freshwater and saltwater macroalgae.
2. The method for making macroalgal attachment material of claim 1, wherein motion of the heating element is paused during its travel from the first location to the second location such that the resulting shape of the lump is altered.
3. The method for making macroalgal attachment material of claim 2, wherein the heating element is paused 0.5-5 seconds at a distance of 1-10 mm from the first location.
4. The method for making macroalgal attachment material of claim 2, wherein the heating element moves away from the lump in such a way as to leave a hairline thread extending from the lump.
5. The method for making macroalgal attachment material of claim 4, wherein the hairline threads are directed to be in a substantially uniform direction and are substantially non-touching.
6. The method for making macroalgal attachment material of claim 4, wherein the hairline threads are directed to be in a substantially non-uniform direction and are substantially attached to one another.
7. The method for making macroalgal attachment material of claim 1, wherein the method uses a melting-filament 3D printer.
8. The method for making macroalgal attachment material of claim 1, wherein the polymer is PETG.
9. The method for making macroalgal attachment material of claim 1, wherein the heated bed temperature is more than 130 C.
10. The method for making macroalgal attachment material of claim 1, wherein steps (i) through (iv) result in lumps on a solid polymer sheet, the solid polymer sheet having a planar bottom surface.
11. The method for making macroalgal attachment material of claim 10, further comprising:



67

(vi) performing steps (i) through (iv) again such that a second planar sheet of solid polymer with lumps is formed, the second solid polymer sheet also having a planar bottom surface;

(vii) adhering the bottom planar surface of the first sheet of solid polymer to the bottom planar surface of the second sheet of polymer such as to form a single thicker sheet of solid polymer with lumps on both sides.

12. A macroalgal attachment material, comprising:

a first sheet of polymer, the first sheet of polymer having a top surface and a bottom surface;

a plurality of lumps positioned on the top surface of the first sheet of polymer,

whereby the lumps of polymer provide attachment points for freshwater and saltwater macroalgae.

13. The macroalgal attachment material of claim 12, wherein the lumps extend 1-5 mm from the top surface of the sheet of polymer.

14. The macroalgal attachment material of claim 12, wherein the lumps are 1-5 mm in diameter.

15. The macroalgal attachment material of claim 12, wherein a plurality of lumps have a hairline thread extending from the lump.

16. The macroalgal attachment material of claim 15, wherein the hairline threads are in a substantially uniform direction and are substantially non-touching.

17. The macroalgal attachment material of claim 15, wherein hairline threads are in a substantially non-uniform direction and are substantially attached to each other.

18. The macroalgal attachment material of claim 12, wherein the polymer is PETG.

19. The macroalgal attachment material of claim 12, further comprising:

a second sheet of solid polymer, the second sheet of solid polymer having a top surface and a planar bottom surface;

a plurality of lumps positioned on the top surface of the second sheet of polymer,

an attachment mechanism, the attachment mechanism to attach the planar bottom surface of the first sheet of solid polymer to the planar bottom surface of the second sheet of solid polymer.

20. The macroalgal attachment material of claim 12, wherein the sheet of solid polymer includes one or more grommets as a single unified component with the polymer sheet.

21. A method for making macroalgal attachment material, comprising:

(i) elevating the temperature of a heating element above the melting temperature of a solid polymer;

(ii) moving the heating element to a first location on the solid polymer, the first location enabling the heating element to be in mechanical contact with the solid polymer for a sufficient amount of time to melt the solid polymer such that the resulting melted polymer adheres to the heating element;

(iii) moving the heating element to a second location of solid polymer such that melted polymer that is adhered to the heating element is stretched from the first location to the second location, the melted polymer then having a first end and a second end, and also such that the path of the stretched melted polymer crosses a void.

(iv) placing the heating element in mechanical contact with solid polymer at the second location for sufficient time to weld the second end of melted polymer to the solid polymer at the second location;

68

(v) removing the heating element from the second location of solid polymer so as to enable the stretched melted polymer to solidify into a hairline thread;

(vi) repeating steps (i) through (v) until a desired number of hairline threads have been created.

22. The method for making macroalgal attachment material of claim 21, wherein the resulting stretched and solidified polymer is a hairline thread less than 0.5 mm in diameter.

23. The method for making macroalgal attachment material of claim 21, wherein the hairline threads are attached to a polymer sheet with a non-porous backing.

24. The method for making macroalgal attachment material of claim 21, wherein the hairline threads are attached to a polymer sheet that is porous.

25. The method for making macroalgal attachment material of claim 21, wherein the polymer is PETG.

26. The method for making macroalgal attachment material of claim 21, wherein the process uses a melting-filament 3D printer.

27. The method for making macroalgal attachment material of claim 21, wherein steps (i) through (iv) result in a first solid polymer sheet and attached hairline threads, the first solid polymer sheet having a planar bottom surface;

28. The method for making macroalgal attachment material of claim 27, further comprising the steps of:

(vii) performing steps (i) through (vi) again such that a second sheet of solid polymer with hairline threads is formed, the second solid polymer sheet also having a planar bottom surface;

(viii) adhering the bottom planar surface of the first sheet of solid polymer to the bottom planar surface of the second sheet of solid polymer such as to form a single thicker sheet of solid polymer with hairline threads on both sides.

29. The method for making macroalgal attachment material of claim 21, wherein the sheet of solid polymer is non-porous.

30. The method for making macroalgal attachment material of claim 21, wherein the sheet of solid polymer is porous.

31. A macroalgal attachment material, comprising:  
a first sheet of solid polymer, the top surface of the first sheet of solid polymer having shapes which form voids;

a plurality of hairline threads, each hairline thread crossing a void and connecting to solid polymer on each end of the hairline thread;

whereby the hairline threads provide surfaces for freshwater and saltwater macroalgae to attach.

32. The macroalgal attachment material of claim 31, wherein the polymer is PETG.

33. The macroalgal attachment material of claim 31, wherein the first sheet of solid polymer sheet has a planar bottom surface.

34. The macroalgal attachment material of claim 31, wherein the first sheet of solid polymer sheet is non-porous.

35. The macroalgal attachment material of claim 31, wherein the first sheet of solid polymer sheet is porous.

36. The macroalgal attachment material of claim 31, wherein the first sheet of solid polymer defines cross members.

37. The macroalgal attachment material of claim 36, wherein the cross members are at right angles to one another.

38. The macroalgal attachment material of claim 33, further comprising:

69

a second sheet of solid polymer, the bottom surface of the second sheet of solid polymer having a planar surface, and the top surface of the second sheet of solid polymer having shapes which form voids;

a plurality of hairline threads, each hairline thread crossing a void and connecting to solid polymer on each end of the hairline thread;

an attachment means, the attachment means to attach the bottom planar surface of the first sheet of polymer to the bottom planar surface of the second sheet of polymer such as to form a single thicker sheet of polymer with connected hairline threads on both sides;

whereby the hairline threads provide attachment points for freshwater and saltwater macroalgae.

39. The macroalgal attachment material of claim 31, wherein the sheet of solid polymer includes one or more grommets.

40. A method for making macroalgal attachment material, comprising:

(i) utilizing a melting-filament 3D printer nozzle to extrude a first extrusion of melted polymer such that the first extrusion welds to a first location on a solid polymer;

(ii) extruding the nozzle at a second location on the solid polymer such that the melted polymer welds to the second location of solid polymer, and also such that a pathway from the first location to the second location crosses a void, thereby extruding a bridge;

(iii) moving the nozzle away from the second location such that the extruded bridge solidifies;

(iv) extruding at least a second extrusion on top of the first extrusion, the second extrusion to weld to and thicken the first extrusion;

(v) repeating steps (i) through (iv) a plurality of times at different locations on the solid polymer until the desired number of bridges have been constructed;

whereby the resulting polymer bridges provide surfaces for freshwater and saltwater macroalgae to wrap around.

41. The method for making macroalgal attachment material of claim 40, wherein the cross section of the resulting passage under each bridge is less than 10 square mm.

42. The method for making macroalgal attachment material of claim 40, wherein the polymer is PETG.

43. The method for making macroalgal attachment material of claim 40, wherein the resulting plurality of solidified polymer bridges defines a first sheet, the first sheet having a top surface and a planar bottom surface, the top surface containing the bridges.

44. The method for making macroalgal attachment material of claim 43, further comprising:

(vi) repeating steps (i) through (v) so as to form a second sheet of solidified polymer, the second sheet having a top surface and a planar bottom surface, the top surface containing the polymer bridges;

(vii) adhering the planar bottom surface of the first sheet of polymer to the planar bottom surface of the second sheet of polymer such as to form a single thicker sheet of polymer that has polymer bridges on both sides.

whereby the resulting polymer bridges provide surfaces for freshwater and saltwater macroalgae to wrap around.

45. The method for making macroalgal attachment material of claim 44, wherein the resulting thicker sheet of solid polymer is non-porous.

46. The method for making macroalgal attachment material of claim 44, wherein the resulting thicker sheet of solid polymer is porous.

70

47. A macroalgal attachment material, comprising:

a first sheet of solid polymer; the first sheet of solid polymer having a top surface and a planar bottom surface; a plurality of polymer bridges welded to the top surface; whereby the bridges provide attachment surfaces for freshwater and saltwater macroalgae to wrap around.

48. The macroalgal attachment material of claim 47, wherein cross sectional area of the passage under each bridge is less than 10 square mm.

49. The macroalgal attachment material of claim 47, wherein a concentration of polymer bridges is at least 2 per square cm.

50. The macroalgal attachment material of claim 47, wherein the first sheet of solid polymer is porous.

51. The macroalgal attachment material of claim 47, wherein the first sheet of solid polymer is non-porous.

52. The macroalgal attachment material of claim 47, wherein the polymer is PETG.

53. The macroalgal attachment material of claim 47, further comprising a second sheet of solid polymer; the second sheet of solid polymer having a top surface and a planar bottom surface;

a plurality of polymer bridges welded to the top surface of the second sheet of solid polymer;

an attachment means, the attachment means to attach the planar bottom surface of the first sheet of solid polymer to the planar bottom surface of the second sheet of solid polymer such that the resulting thicker sheet of solid polymer has polymer bridges on both sides;

whereby the polymer bridges provide attachment surfaces for freshwater and saltwater macroalgae to wrap around.

53. The macroalgal attachment material of claim 47, wherein the macroalgal attachment material includes one or more grommets.

54. A method for instructing a melting-filament 3D printer to print macroalgal attachment material, comprising using three or more of the following techniques:

No filament retraction is used;

Nozzle temperature is higher than 240 C;

Polymer is PETG;

Non-printing travel moves are less than 30 mm per second;

Nozzle wiping is not used;

Printing is done in sequential 2x2 cm squares, where each 2x2 cm square is completed from first bottom layer to last top layer before the next 2x2 cm square is started;

Extrusion is set to be over-extruded by at least 20 percent;

Heated bed temperature is higher than 130 C;

Non-printing travel moves are allowed to cross already-printed areas;

Nozzle orifice diameter is 0.5 mm or larger;

Whereby the resulting solidified polymer material will provide attachment surfaces for freshwater and saltwater macroalgae.

55. A macroalgal attachment material substantially as hereinbefore described with reference to FIGS. 28-29.

While certain embodiments have been described and shown in the accompanying drawings, it is to be understood that such embodiments are merely illustrative of and not restrictive on the broad invention, and that the invention is not limited to the specific constructions and arrangements shown and described, since various other modifications may occur to those of ordinary skill in the art. The description is thus to be regarded as illustrative instead of limiting. Further, referenced patents and applications are incorporated herein by reference in their entirety. Where a definition or use of a term in a reference, which is incorporated by reference herein is inconsistent or contrary to the definition

of that term provided herein, the definition of that term provided herein applies and the definition of that term in the reference does not apply. Nothing herein is to be construed as an admission that the present invention is not entitled to antedate such references by virtue of prior invention.

The invention claimed is:

1. An apparatus for supporting macroalgal attachment material and supplying water to a macroalgal attachment surface, comprising:

- a macroalgal attachment material defining a macroalgal attachment surface configured to hold solid macroalgal roots and to allow liquids to flow;
- a macroalgal settlement structure defining a macroalgal settlement surface;
- a water delivery structure, the water delivery structure intersecting the macroalgal settlement surface;
- a positioning mechanism, the positioning mechanism configured to position the macroalgal attachment material such that the macroalgal attachment surface receives water from the water delivery structure;
- an attachment mechanism, the attachment mechanism configured to couple the macroalgal settlement structure to the water delivery structure and to align the macroalgal settlement surface such that macroalgae is enabled to travel from the macroalgal attachment surface to the macroalgal settlement surface.

2. The apparatus of claim 1, wherein the water delivery structure and the macroalgal settlement structure remain coupled when removed from a water supply source.

3. The apparatus of claim 2, wherein the water delivery structure and the macroalgal settlement structure remain in position relative to each other when removed from a water supply source.

4. The apparatus of claim 1, wherein the macroalgal attachment material is suspended from the water delivery structure.

5. The apparatus of claim 1, wherein the water delivery structure is a water pipe.

6. The apparatus of claim 1, wherein the water delivery structure is a reservoir.

7. The apparatus of claim 1, further comprising solid macroalgal roots attached to the macroalgal attachment surface.

8. A method for supporting macroalgal attachment material and supplying water to a macroalgal attachment surface, comprising the steps of:

- providing a macroalgal attachment material defining a macroalgal attachment surface configured to hold solid macroalgal roots and to allow liquids to flow;
- providing a macroalgal settlement structure defining a macroalgal settlement surface;
- providing a water delivery structure, the water delivery structure intersecting the macroalgal settlement surface;
- providing a positioning mechanism, the positioning mechanism configured to position the macroalgal attachment material such that the macroalgal attachment surface receives water from the water delivery structure;

providing an attachment mechanism, the attachment mechanism configured to couple the macroalgal settlement structure to the water delivery structure and to align the macroalgal settlement surface such that macroalgae is enabled to travel from the macroalgal attachment surface to the macroalgal settlement surface.

9. The method of claim 8, wherein the water delivery structure and the macroalgal settlement structure remain coupled when removed from a water supply source.

10. The method of claim 9, wherein the water delivery structure and the macroalgal settlement structure remain in position relative to each other when removed from a water supply source.

11. The method of claim 8, wherein the macroalgal attachment material is suspended from the water delivery structure.

12. The method of claim 8, wherein the water delivery structure is a water pipe.

13. The method of claim 8, wherein the water delivery structure is a reservoir.

14. The method of claim 8, wherein the macroalgal attachment material is pushed upwards by the macroalgal settlement structure.

15. An apparatus for supporting macroalgal attachment material and supplying water to a macroalgal attachment surface, comprising:

- a macroalgal attachment material defining a macroalgal attachment surface configured to hold solid macroalgal roots and to allow liquids to flow;
- a macroalgal settlement structure defining a macroalgal settlement surface;
- a water delivery structure, the water delivery structure intersecting the macroalgal settlement surface;
- a positioning mechanism, the positioning mechanism configured to position the macroalgal attachment material such that the macroalgal attachment material is pushed upwards by the macroalgal settlement structure and such that the macroalgal attachment surface receives water from the water delivery structure;
- an attachment mechanism, the attachment mechanism configured to couple the macroalgal settlement structure to the water delivery structure and to align the macroalgal settlement surface such that macroalgae is enabled to travel from the macroalgal attachment surface to the macroalgal settlement surface.

16. The apparatus of claim 15, wherein the water delivery structure and the macroalgal settlement structure remain coupled when removed from a water supply source.

17. The apparatus of claim 16, wherein the water delivery structure and the macroalgal settlement structure remain in position relative to each other when removed from a water supply source.

18. The apparatus of claim 15, wherein the water delivery structure is a water pipe.

19. The apparatus of claim 15, wherein the water delivery structure is a reservoir.

20. The apparatus of claim 15, further comprising solid macroalgal roots attached to the macroalgal attachment surface.